



# THE INDISPENSABLE DISPENSING GUIDE

The Eyecare Provider's Basic Dispensing Guide

3rd Edition

*From your lab partner, a member of The Vision Council*



\$119.95

# ESSENTIAL PRODUCTS FOR YOUR PRACTICE

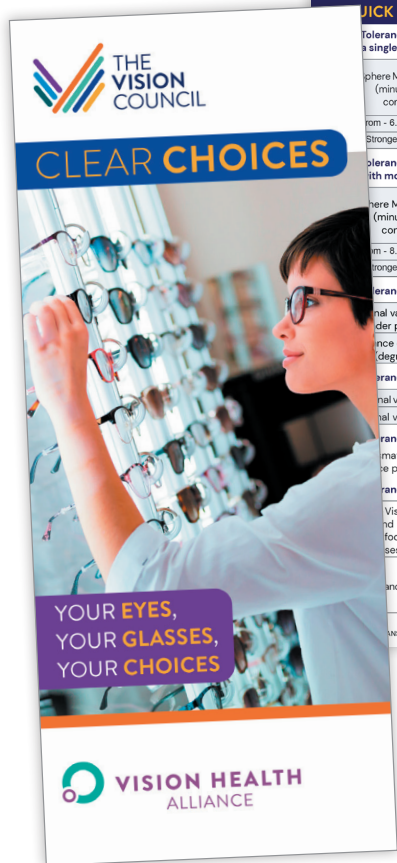

**THE VISION COUNCIL**

**QUICK REFERENCE GUIDE -- ANSI Z80.1-2020**

Tolerance on Distance Refractive Power (Single Vision, Multifocal and Power Variation Lenses with a single reference point)

Sphere Meridian Power (minus cylinder convention)	Tolerance on Sphere Meridian Power (minus cylinder convention)	Cylinder $\geq 0.00$ D $\leq -2.00$ D	Cylinder $> -2.00$ D $\leq -4.50$ D	Cylinder $> -4.50$ D
from - 8.50 D to + 8.50 D	$\pm 0.13$ D	$\pm 0.13$ D	$\pm 0.15$ D	$\pm 4\%$
Stronger than $\pm 8.50$ D	$\pm 2\%$	$\pm 0.13$ D	$\pm 0.15$ D	$\pm 4\%$

Tolerance on Distance Refractive Power (Power Variation Lenses "Progressive Addition Lenses" with more than one reference point)

Sphere Meridian Power (minus cylinder convention)	Tolerance on Sphere Meridian Power (minus cylinder convention)	Cylinder $\geq 0.00$ D $\leq -2.00$ D	Cylinder $> -2.00$ D $\leq -3.50$ D	Cylinder $> -3.50$ D
from - 8.00 D to + 8.00 D	$\pm 0.16$ D	$\pm 0.16$ D	$\pm 0.18$ D	$\pm 5\%$
Stronger than $\pm 8.00$ D	$\pm 2\%$	$\pm 0.16$ D	$\pm 0.18$ D	$\pm 5\%$

Tolerance on direction of cylinder axis

**THE VISION COUNCIL**

**EPIC**  
ELECTRONIC PROGRESSIVE IDENTIFIER CHART

**Progressive Identifier Search**

Search:  Organization:



**AO b'Active**

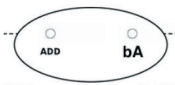

This lens was discontinued in 2010

**Materials:** Plastic (CR39 and 1.50)

**Standard Progressive PAL Design on Front side**  
Fitting cross location: 2mm above 180 line  
Rec. minimum fitting height: 18mm

Available as: Clear  
Available in: US and Canada

**Clear Choices Brochure – YOUR Eyes. YOUR Glasses. YOUR Choices.**  
A patient brochure which provides clear, understandable information about lens material, design, and treatment options.

**ANSI Z80.1-2020 Quick Reference Guide**  
A guide which provides the tolerances for dress eyewear as defined by the ANSI Z80.1-2020 standard; available to download as a PDF.

**Electronic Progressive Identifier Chart (EPIC)**  
Our most requested resource, the Progressive Identifier Chart is now available in electronic form. This new offering allows for real-time updates, so even the most recently released lens designs are included. Visit [epic.thevisioncouncil.org](http://epic.thevisioncouncil.org), and be sure to add it to your favorites for easy access.

**'Multiple Pairs' In-Office Poster Series**  
Educate patients on the need for multiple pairs of glasses and various lens offerings with these posters for use in ECP offices.



**Your lab partner, a member of The Vision Council, is the best source for these products. Call your lab today!**



# THE INDISPENSABLE **DISPENSING GUIDE**

The Eyecare Provider's Basic Dispensing Guide

3rd Edition

*From your lab partner, a member of The Vision Council*

# THE INDISPENSABLE DISPENSING GUIDE

The Eyecare Provider's Basic Dispensing Guide

3rd Edition

*From your lab partner, a member of The Vision Council*

**Revised and Edited by**

Brad Main, FNAO and Michael C. Vitale, ABOM

# TABLE OF CONTENTS

## The Eyecare Provider's Basic Dispensing Handbook

<b>Eyecare Providers</b>	<b>3</b>
Introduction	3
The Ophthalmologist	3
The Optometrist	3
The Optician	3
<b>History of Eyewear</b>	<b>3</b>

## Overview of an Optical Laboratory

<b>The Route Your Rx Travels Through the Laboratory</b>	<b>5</b>
<b>Customer Service</b>	<b>5</b>
<b>Surfacing Department</b>	<b>5</b>
<b>Finishing Department</b>	<b>6</b>
<b>Rx Flow Chart</b>	<b>7</b>

## The Eye and The Prescription

<b>Major Parts of the Eye</b>	<b>8</b>
<b>The Normal (Emmetropic) Eye</b>	<b>9</b>
<b>The Farsighted Eye</b>	<b>9</b>
<b>The Nearsighted Eye</b>	<b>10</b>
<b>Astigmatism</b>	<b>10</b>
<b>Presbyopia</b>	<b>11</b>
<b>Review: The Plus Lens</b>	<b>11</b>
<b>Review: The Minus Lens</b>	<b>12</b>
<b>Review: The Sphero-cylinder Lens</b>	<b>12</b>

## Overview of Lenses

<b>Comparing Lens Materials</b>	<b>13</b>
Thickness	13
Weight	14
Transmission of Radiant Energy	14
Optical Performance	14
<b>Lens Materials</b>	<b>15</b>

Plastic CR-39®	15
Mid-index Plastics	15
Trivex®	15
Polycarbonate	15
High Index Plastics	16
Glass	16
High Index Glass	16
Other Materials and Questions	16

## Styles **17**

Single vision lenses	17
Aspheric Designs	17
Atoric, Bi-toric or Bi-aspheric Designs	17
Progressive Lenses (PALS)	17
Conventional PAL Design	18
Free Form Lens Design and Digital Surfacing	18
Bifocals	19
Trifocals	19
Occupational, Task-Specific or Variable Focus Lenses	19
Specialty Lenses	20

## Lens Enhancements **20**

Scratch Resistant Treatment (S/R)	20
Anti-Reflection Treatment (A/R)	20
Ultraviolet Protection (UV) Treatment	21
Filters/Tints	21
Color Coatings	22
Mirror Coatings	22
Photochromic Lenses	22
Polarized Sun Lenses	22
Edge Treatments	22

## Eyewear Selection

<b>Lifestyle Considerations</b>	<b>23</b>
---------------------------------	-----------

# TABLE OF CONTENTS

<b>Rx Evaluation</b>	<b>23</b>	Bridge Types	30
<b>Presentation Process</b>	<b>23</b>	<b>The Temple</b>	<b>31</b>
Step One: Know Your Products	24	Library Temple	31
Step Two: Present Value, Not Products	24	Skull Temple	31
Step Three: Present the Complete Lens	24	Riding Bow Temple	31
<b>Facial Measurements and Frame Selection</b>		Comfort Cable	31
<b>Facial Measurements</b>	<b>25</b>	Frame Selection	32
PD Measurements	25	Optical Performance	32
Fitting Height Measurements	26	<b>From Rx to Eyewear</b>	
<b>Frame Selection</b>	<b>27</b>	<b>The Doctor's Prescription</b>	<b>34</b>
Frame Measurements	28	<b>The Laboratory Order</b>	<b>34</b>
Review: Measurements	28	Patient Information	34
<b>Decentration – Frame Size vs. Patient's PD</b>	<b>28</b>	Lens Information	35
<b>Frame Materials and Styles</b>	<b>28</b>	Frame Information	35
Frame Materials	28	Other Information	35
Plastic	28	<b>Conclusion</b>	<b>35</b>
Cellulose Acetate	28	<b>Delivery of Eyewear to the Patient</b>	
Propionate	28	<b>Frame Alignment Process</b>	<b>36</b>
Nylon	29	To place a frame in standard alignment	36
Metals	29	Nosepads	37
Titanium	29	<b>Adjustment for Alignment</b>	<b>38</b>
Stainless Steel	29	New Delivery	38
Monel	29	Review	38
<b>Frame Selection for Cosmetics and Fit</b>	<b>29</b>	Readjustments	38
Full Frames	29	<b>Glossary of Terms</b>	
Drilled Rimless Frames	29	<b>Common Optical Terms and Abbreviations</b>	<b>39</b>
Grooved Rimless Frame	29	<b>Index</b>	<b>40</b>
Combination Frame	29		
Half-Eye Frame	30		
Sports Frames	30		
Wrap Frames	30		
Safety Frames	30		

# THE EYECARE PROVIDER'S BASIC DISPENSING HANDBOOK

## Eyecare Providers

### Introduction

The three most commonly recognized eyecare providers (ECPs) are the ophthalmologist (of thal MOL e jist), the optometrist (op TOM i trist), and the optician (op TISH en). Though they are often confused, they are separate professions.

### The Ophthalmologist

An ophthalmologist is sometimes called an “eye M.D.” because he or she is a medical doctor who specializes in eye and vision care. “Eye M.D.s are specially trained to provide the full spectrum of eyecare, from prescribing glasses and contact lenses to complex and delicate eye surgery. Many eye M.D.’s are also involved in scientific research into the causes and cures for eye diseases and vision problems.”

Source: [www.aao.org/about/eyemds.cfm](http://www.aao.org/about/eyemds.cfm)

### The Optometrist

Optometrists are state-licensed health care professionals who diagnose and treat eye health and vision problems. They prescribe glasses, contact lenses, low-vision rehabilitation, vision therapy and medications, as well as perform certain surgical procedures. They hold the doctor of optometry (O.D.) degree.

Source: <https://www.aoa.org/optometrists>

### The Optician

An optician is a professional in the field of fitting and dispensing eyeglass lenses, frames, and contact lenses. An optician uses a doctor’s prescription to fit and dispense prescription eye glasses and/or contact lenses. They may also dispense low-vision aids and artificial eyes.

Source: [www.oaa.org](http://www.oaa.org)

## History of Eyewear

The idea of eyewear was first conceived sometime near the end of the thirteenth century. At first, very few people wore eyewear. The eyewear was rather strange looking and was viewed with suspicion by many. In the Middle Ages, science was thought to be demonic, and scientific developments were largely ignored.

Early in the seventeenth century (1600s) the first trade guild was formed in Germany and by the end of the century the first optical stores opened for business. Nose glasses started to appear as eyewear slowly became more generally accepted by the public.

By the beginning of the nineteenth century there was some general understanding of visual and ocular anatomy, but modern eyewear did not really arrive on the scene until the mid-1800s. The primary work was done by a Dutch ophthalmologist, Dr. Donders, and a German professor, Professor Helmholtz. Between them they established the basis of what we know about the healthy eye and how it works.

The 1900s saw huge advancements in lens materials and designs as well as in frame styles and materials. In the early 1900s, corrected curve lenses were introduced and provided far better vision than previous lenses. Also during this time period fused bifocal segments on glass lenses became popular. Plastic and gold-filled metal were widely used for frames.

By mid-century, lightweight plastic lenses were offered and cellulose acetate (zyl) frames were introduced. Photochromic glass lenses were invented during this time period and progressive lenses with no visible lines were offered and quickly became popular.

During the last part of the twentieth century there were a number of new developments including:

- Polycarbonate lens material became popular for ophthalmic prescriptions;
- Different metal alloys and materials for metal and plastic frames were used;
- Soft contact lenses were introduced;
- Rigid Gas Permeable contact lenses, called RGPs, were developed, allowing oxygen permeability;
- Plastic photochromic lenses were introduced; and
- Aspheric lens designs became popular.

The beginning of the 21st century has brought even more advanced technology that has dramatically improved the cosmetics and visual performance of spectacle lenses. Various mid and high index plastics, photochromics and “personalized” single vision and progressive lens designs provide the eyecare provider with a vast array of products that better correct and protect vision.

As you can see, the optical industry has been very active during the last hundred years and will continue bringing out innovative products. Current lenses and frames materials will be discussed in detail later in this manual.

The optical laboratory plays a major part in the ever-changing field of vision. Today’s optical laboratory services go beyond just making lenses. Laboratories provide products and services in instrumentation, accessories, education, buying groups, frame products, contact lenses, dispensing fixtures and office design. Along with providing a variety of products and services to your office, the optical laboratory serves as a consultant to manufacturers, providing insight and making recommendations to help bring out the best equipment to process lenses.

## NOTES

---

---

---

---

---

---

---

---

---

---

---

---

---

---

---

---

---

---

---

---

---

---

---

---

---

---

---

---

---



# OVERVIEW OF AN OPTICAL LABORATORY

## The Route Your Rx Travels Through the Laboratory

Patients may ask, "Why can't I get my glasses right away?" They often don't realize all the steps and the number of people it takes to produce their eyewear. The steps necessary to produce the final product are determined by many factors, including frame and lens selection, facial measurements, lens treatments and the Rx. The flow of a typical Rx through the lab is described on page seven. Standards must be met in each area and there can be delays if they are not met.

## Customer Service

Usually the first point of contact with the lab is customer service. The order is received from the ECP by phone, fax, mail, e-mail or internet-based online ordering and is entered into the computer system. Electronic or internet-based ordering web sites have grown in popularity for placing orders with the optical lab, frame vendors and contact lens suppliers. Electronic ordering can optimize service delivery times by reducing ordering mistakes, provide lens availability menus and place orders directly into the lab's processing system. Many of these services can also provide the ECP with real time status of their orders 24 / 7..

The lenses and frames are picked from the stock or they are ordered from the manufacturers. The order is tracked by bar code at the designated stations during the process to provide up-to-date information on the order's location in the lab. If the order was placed via online ordering, information about the order's location in the lab is transmitted to the website.

The order then enters the processing part of the lab in one of two departments, surfacing or finishing, depending on the type of lenses selected to complete the order. Semi-finished lenses must first go through the surfacing department to have the back surfaces ground before being sent to the finishing department. Finished lenses go through the finish department only because both sides of the lenses are already ground.

## Surfacing Department

There are two types of surfacing technologies that can be in the modern optical laboratory; Conventional and Digital.

### Conventional Surfacing

In conventional surfacing, the back surface of a semi-finished (SF) lens blank will be fined (smoothed) and polished using a hard block – or tool – to create the necessary curves for the required prescription. The front surface (curve) of the SF lens blank is molded to a specific curve called the base curve. Each base curve will be optically suitable for a range of powers when mathematically combining the optimized front and back curves. The front surface of the SF blank will also feature the lens design; single vision, lined multi-focals, progressives and special purpose. Labs must stock a large number of lens blanks to generate a wide variety of designs, materials, base curves and addition powers when they conventionally surface.

### Digital Surfacing

A digital generator – sometimes referred to as free form generating– will grind the back surface, front surface or both surfaces of the lens blank with a diamond point tool. Utilizing this technology, lens designers can create complex lens designs such as aspheric, atoric and progressive lenses that can be customized to the need of the individual power and personal needs of the wearer all on a single vision SF lens blank. This greatly reduces the number of SF lens blanks the lab must keep in inventory.

### Conventional or digital surfacing follows similar steps in processing:

- **Mark-up** – Reference points are located on the lens
- **Blocking** – A block is attached to the lens
- **Generating** – The surface curves are cut. In conventional, back only. Digital can be back, front or both.
- **Fining** – The surface curves are smoothed. (Digital surfacing is less abrasive to the lens surfaces and fining is not required)
- **Polishing** – The surface curves are polished.
- **Deblocking** – The block is removed and the lens is cleaned.
- **Inspection** – Optical characteristics are checked to standard.



# RX Flow Chart

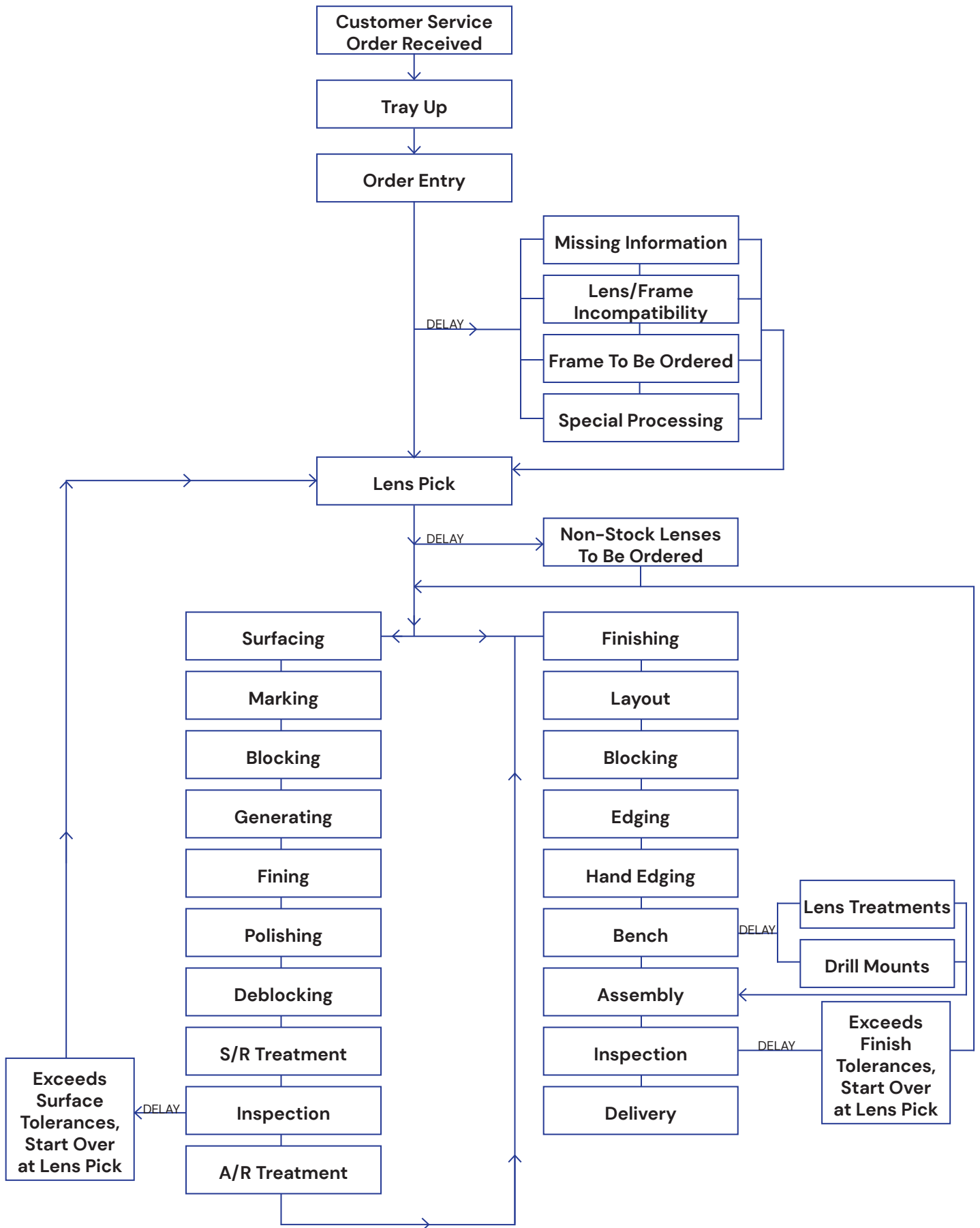

# THE EYE AND THE PRESCRIPTION

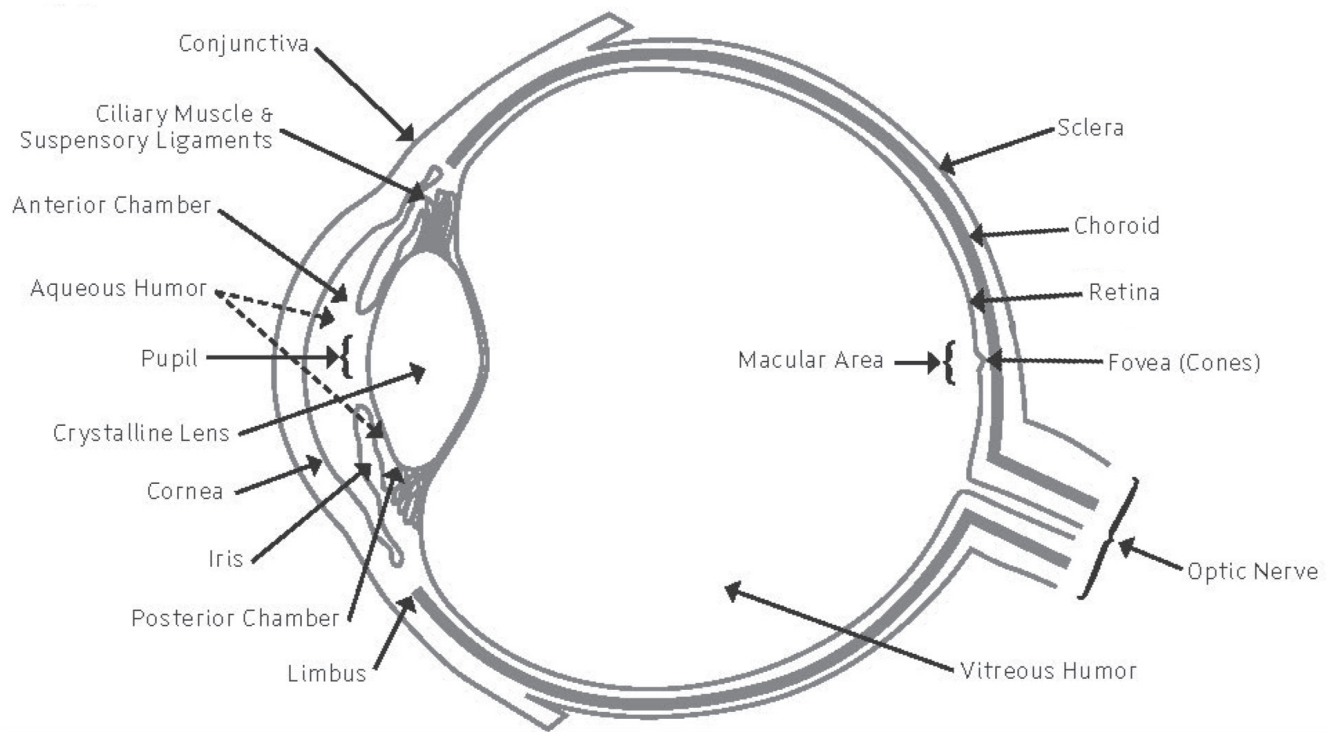

## Major Parts of the Eye

- **Anterior Chamber** – The space in the eye between the front surface of the iris and the inner surface of the cornea; the space is filled with aqueous humor.
- **Aqueous Humor** – A watery fluid in the anterior and posterior chambers that is involved in the metabolism of the cornea and the lens.
- **Choroid** – A middle layer of the eye consisting of a pigment layer and blood vessels supplying nourishment to the outer layers of the retina.
- **Ciliary Muscle** – Smooth muscle portion of the ciliary body responsible for near-vision focusing.
- **Conjunctiva** – A thin mucous membrane that covers the inner surface of the eyelid and extends over the exposed surface of the sclera.
- **Cornea** – The transparent structure forming the anterior part of the eye.
- **Crystalline Lens** – A biconvex body suspended directly behind the pupil. This body accounts for one-third of the total eye power.
- **Fovea** – A depression in part of the macula adapted for most acute vision and color discrimination.
- **Iris** – The pigment or color anterior component surrounding the central opening (pupil). Controls the amount of light reaching the pupil by changing diameter.
- **Limbus** – A border, edge or junction often distinguished by color.
- **Macula Area** – An oval area in the posterior polar retina. It is three to five millimeters in diameter and located slightly temporally.
- **Optic Nerve** – The nerve that connects the retina to the brain.
- **Posterior Chamber** – The space between the back surface of the iris and the suspensory ligaments, it is filled with aqueous humor.
- **Pupil** – The opening in the iris that varies in size depending on light and other conditions.
- **Retina** – The innermost layer of the eye on which light rays come to a focus.
- **Sclera** – The white, opaque, fibrous, outer tunic of the eyeball.
- **Suspensory Ligaments** – Suspensory fibers that connect the crystalline lens capsule to the ciliary body.
- **Vitreous Humor** – The gelatinous, colorless, transparent substance filling the vitreous chamber of the eye.

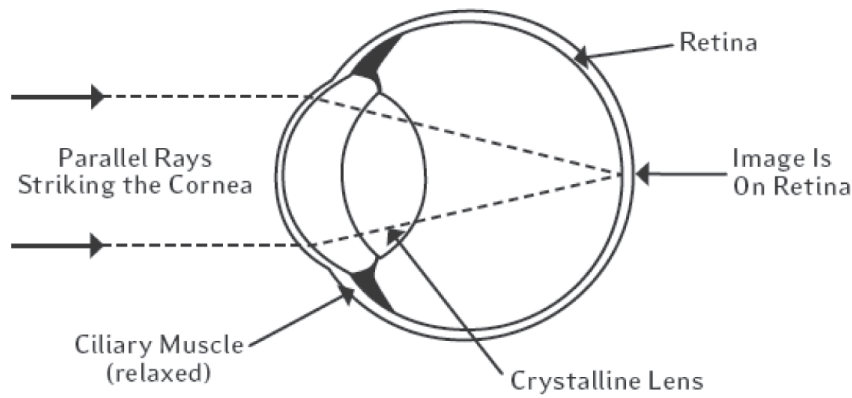

Figure 3-1, The normal (Emmetropic) Eye

## The Normal (Emmetropic) Eye

A spectacle lens supplements the eye's normal function of focusing light. It helps the eyes perform functions that the eye cannot do by itself. Therefore, to understand the function of lenses, you must understand how the normal eye works. Figure 3-1 shows some parts of the normal, or emmetropic (em i TROP ic), eye. Study it carefully before you proceed.

Figure 3-1 also shows light as it enters the eye from distant objects. Rays of light from distant objects proceed to the eye along parallel lines. When they reach the eye they are bent, or refracted, by the cornea. These rays of light are refracted even further by the crystalline lens and are sharply focused on the retina at the back of the eye.

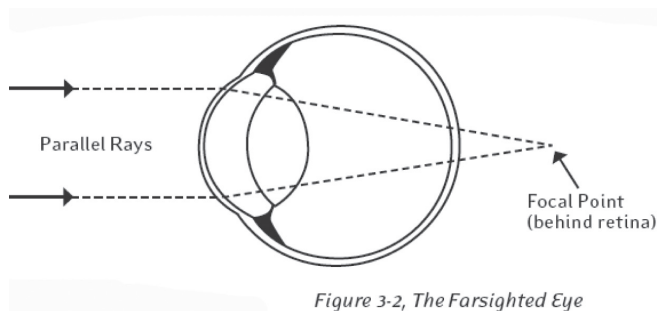

Figure 3-2, The Farsighted Eye

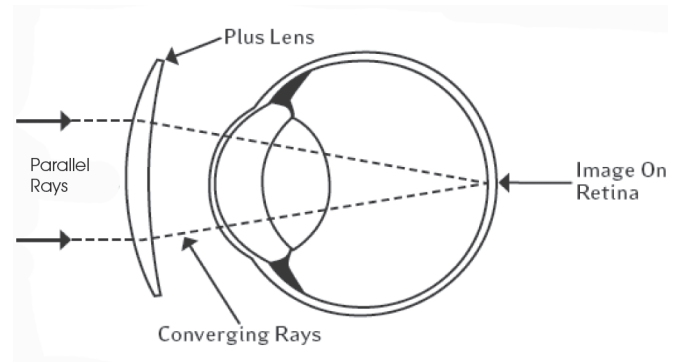

Figure 3-3, The Farsighted Eye – Corrected

## The Farsighted Eye

There are a variety of reasons why light sometimes does not focus precisely on the retina. Some of these reasons have to do with the shape of the eyeball itself. For example, people who have little problem with distance vision, but do have problems close-up, are called farsighted, or hyperopes (HY per ops). The hyperopic (hy per O pik) eye may be thought of as an optically weak power system. The result is that light seems to come to a focus behind the retina, causing the image to blur. This problem, which is quite common, is illustrated in Figure 3-2.

Figure 3-3 shows an eye that has been corrected for hyperopia (hi per O pe a) by adding a converging lens. The lens helps the eye by converging or redirecting the focus of the light forward to the retina to produce a clear image. Converging lenses are convex and are called plus lenses. With the normal accommodation of the crystalline lens, and the help of the corrective lens, the eye can now focus clearly upon near and distant objects with little eye strain.

## The Nearsighted Eye

The other common condition which causes blurred vision is nearsightedness, or myopia (mi O pe a). The nearsighted eye may be thought of as an optically strong power system causing the light rays to focus in front of the retina. The nearsighted eye is shown in Figure 3-4.

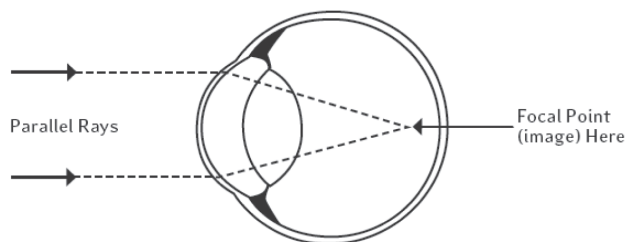

Figure 3-4, The Nearsighted (Myopic) Eye

Although a nearsighted person may be able to clearly see objects held close to the eye, objects in the distance will appear blurred. Nearsightedness is corrected using a concave diverging lens, called a minus lens, as shown in Figure 3-5. The diverging lens spreads the rays of light farther apart so that they converge on the retina rather than in front of it.

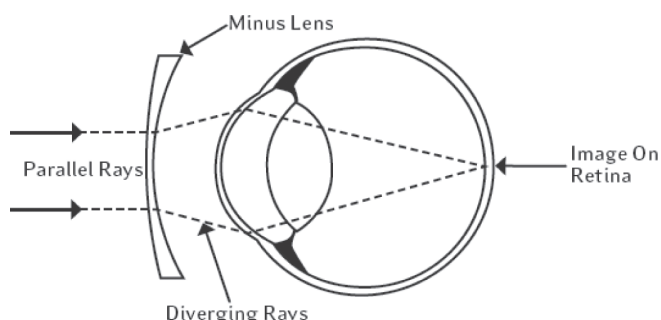

Figure 3-5, The Nearsighted Eye – Corrected

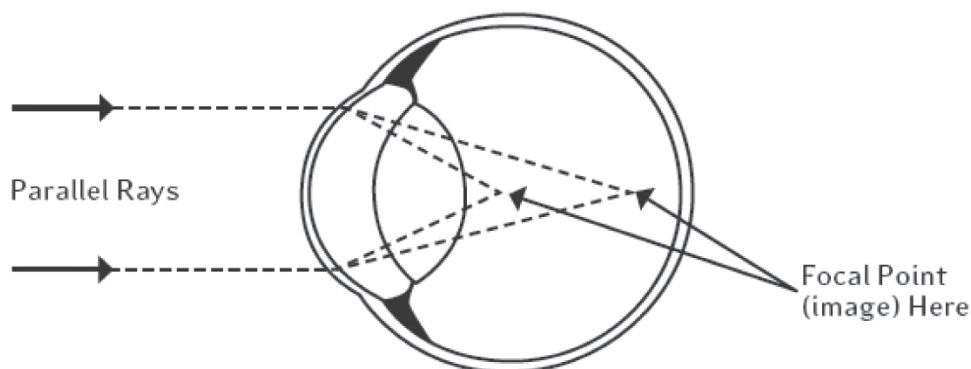

Figure 3-6, Astigmatism

## Astigmatism

Up to this point, the lenses in the eyes we have described have been spherical in nature. Spherical lenses have the same curvature in all directions. However, it is not uncommon for the cornea of the eye to have slightly varying curvature. This produces a condition called astigmatism (a STIG ma tism), which cannot be corrected with the simple spherical lenses just discussed. The uncorrected eye of a patient with astigmatism will not bring light rays to a sharp, well-defined focus on the retina. Objects may appear out of focus differently at right angles.

The cylindrical surface has two different power curves ground at right angles to refocus the two focal points to the retina. This lens is called a spherocylinder lens and also called a compound or toric lens. This spherocylinder lens, when properly oriented before the eye, will cancel the eye's astigmatic refractive power error. Figure 3-6.

## Presbyopia

The lens types considered so far produce a correction primarily for distant objects. Such lenses are called single vision lenses. They rely upon the eye's own crystalline lens to produce clear images of near objects.

The crystalline lens may be stretched or relaxed by the eye muscles. This process is called accommodation. Accommodation allows the normal eye to produce clear images on the retina of objects that are relatively near to the eye as well as those that are distant. The process works in much the same way as the focusing action of a camera.

As people approach middle age, their crystalline lenses lose some elasticity and they begin to have difficulty focusing on books, newspapers, etc. This condition is called presbyopia (prez be O pe a). To solve this condition, lenses with more than one viewing range are used. These lenses are called bifocals, trifocals, progressives, or, more generally,

multifocals (Figure 3-7). A bifocal lens is really two lenses combined into one. The lens provides a distance-viewing area and a near-viewing area. A trifocal provides three viewing areas: distance, intermediate and near.

A progressive lens provides a continuous increase in lens power as the eye moves down from the distance viewing to the near-viewing range. Progressive lenses are sometimes called “no-line” bifocals. More information on lenses is provided in this guide on page 13.

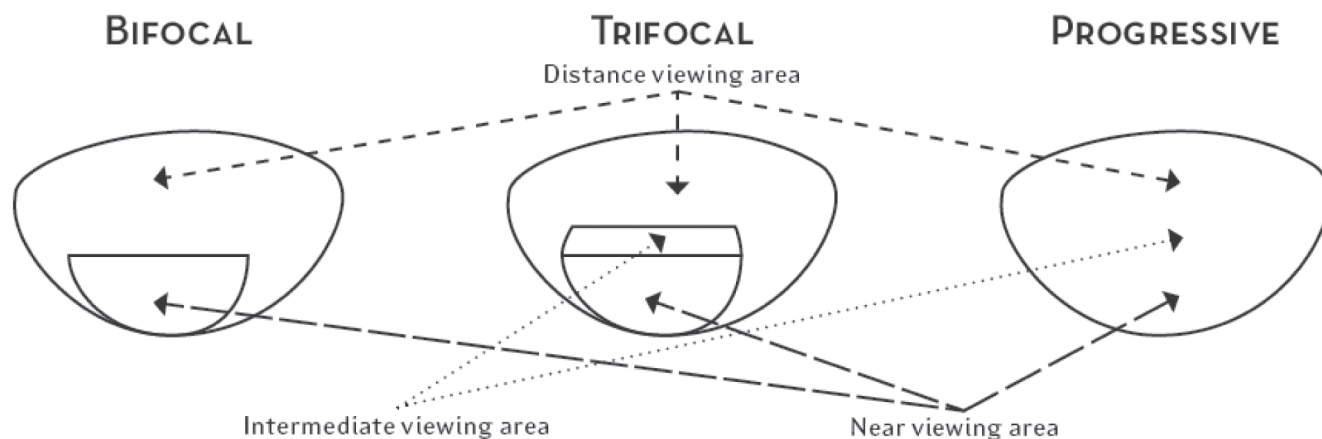

Figure 3-7, Bifocal, Trifocal, and Progressive Lenses

## Review: The Plus Lens

Figure 3-8 is an illustration of a plus lens, also called a converging lens, because in hyperopes it causes light to converge to a point on the retina rather than behind it.

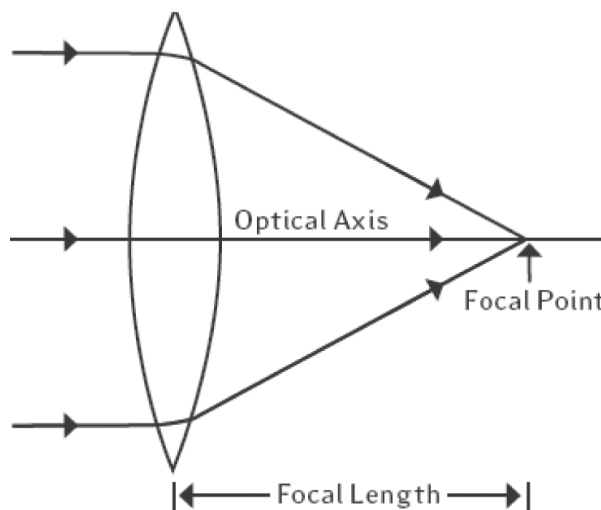

Figure 3-8, The Plus (Converging) Lens





# OVERVIEW OF LENSES

## Comparing Lens Materials

The eyecare provider can look at the characteristics of the available materials and decide which is the best to recommend for the patient. Lens materials can be differentiated by their thickness, weight, transmission of radiant energy and optical performance.

### Thickness

As the prescription increases in power so does the thickness for both plus and minus power lenses. Plus lenses will be thicker in the center and minus lenses will be thicker at the edge. Many important factors can influence the resulting thickness of a lens, even in higher index materials. Proper frame selection that requires minimal amounts of lens decentration (further explained in Decentration – Frame Size vs. Patient PD, page 28), smaller frame eye sizes, center thickness (on minus powers), edge thickness (on plus powers) and aspheric designs go a long way in making the lenses cosmetically pleasing.

Impact resistance is the overriding consideration in lens thickness. All lenses must meet FDA-required impact resistance requirements. Sometimes, the lens thickness is dictated by whether it passes the FDA impact resistance “drop ball” test.

Lens materials are referenced by their bending power. This unit of measure is called the index of refraction or, simply, index. The index of refraction contributes to creating the lens power. The more bending power or the higher the index of the material, the flatter the front and back curves will need to be to create the needed power for the prescription. The end result will be a lens that is thinner than a lower index material.

Figure 4-1 shows the index of refraction of some of the different lens materials. Remember, the higher the index of refraction, the thinner the lens.

Lens Material	Index of Refraction
CR-39® Plastic	1.498
Trivex®	1.530
Mid-index Plastic	1.535-1.560
Polycarbonate	1.586
1.60 Index Plastic	1.594-1.600
1.67 Index Plastic	1.660-1.670
1.70 Index Plastic	1.701
1.74 Index Plastic	1.74
Crown Glass	1.523
1.6 Index Glass	1.601
1.7 Index Glass	1.701
1.8 Index Glass	1.805

4-1, Index of Refraction

## Weight

The weight of a lens material is referenced by the term “density.” Density is a measurement of weight based on a certain amount of material. The same amount, a cubic centimeter, of each lens material is measured for comparison and the weight is referenced in grams. Looking at Figure 4-2, you can make the comparisons based on density. For example, CR-39® plastic is about half the weight of glass.

Lenses of the same material will vary in thickness (amount of material) depending on factors such as lens power, size, shape and facial measurements. A practical way to compare the weight of lens materials is to represent the weight based on power for a determined lens size.

## Transmission of Radiant Energy

There are three regions of the electromagnetic spectrum of concern with ophthalmic lenses – ultraviolet, visible light, and infrared. As radiant energy passes through a lens, light transmission may be blocked, reduced, or not affected in these areas.

The human eye does not see ultraviolet radiation, but the effects of exposure to it can be harmful. Transmission of ultraviolet radiation through ophthalmic lenses may be reduced, blocked or not affected, depending on the lens material. It is important to understand how lens materials affect the transmission of ultraviolet radiation.

Transmission of visible light can be affected by the color of a lens. Different colors can cause overall reduction or specific reduction in the visible region. The infrared area is generally considered not to be harmful to the eye and will not be covered at this time.

## Optical Performance

Lens designers create lenses to provide the best visual performance, cosmetic appearance, and comfort. Proper lens selection, correct facial measurements, and correct frame alignment are all necessary to maintain the design intent. The optical laboratory serves as an important link between the manufacturer and the eyecare provider in providing the latest information on lens performance.

Lens Material	Density
CR-39® Plastic	1.31
Trivex®	1.11
Mid-index Plastic	1.20-1.24
Polycarbonate	1.20
1.60 Index Plastic	1.22-1.24
1.67 Index Plastic	1.35-1.37
1.70 Index Plastic	1.40
1.74 Index Plastic	1.46
Crown Glass	2.54
1.6 Index Glass	2.63
1.7 Index Glass	2.99
1.8 Index Glass	3.37

4-2, Density

# Lens Materials

## Plastic CR-39®

Plastic lenses gained popularity during the 70s due to the fashion trend for large-sized frames and the availability of additional lens styles. Plastic lenses are half the weight of glass lenses, however the lens surface is softer and easier to scratch. Scratch resistant (S/R) coatings provide a harder surface and should be recommended to the patient. Like glass lenses, plastic lenses do not provide UV protection and must be treated to provide such protection.

Positive Points	Negative Points
<ul style="list-style-type: none"> <li>• Half the weight of glass</li> </ul>	<ul style="list-style-type: none"> <li>• Older lens material</li> </ul>
<ul style="list-style-type: none"> <li>• Uniform density in tinting</li> </ul>	<ul style="list-style-type: none"> <li>• Not good for drilled rimless</li> </ul>
<ul style="list-style-type: none"> <li>• Available in a variety of styles</li> </ul>	

## Mid-index Plastics

Mid-index plastic lenses have a higher index of refraction than regular glass or plastic lenses, but a lower index of refraction than high-index materials. This means mid-index materials are thinner than regular glass or plastic but not as thin as a high-index material.

Positive Points	Negative Points
<ul style="list-style-type: none"> <li>• Thinner than regular plastic or glass</li> </ul>	<ul style="list-style-type: none"> <li>• Not as thin as high-index materials</li> </ul>
<ul style="list-style-type: none"> <li>• Most mid-index materials provide UV protection</li> </ul>	<ul style="list-style-type: none"> <li>• Not available in all lens styles</li> </ul>
	<ul style="list-style-type: none"> <li>• Generally the least impact resistant of all plastic lens materials.</li> </ul>

## Trivex® Plastic

Like other mid-index plastics, Trivex® has a higher refractive index than regular plastic lenses (1.53 index versus 1.498) but not as high as polycarbonate or other higher index plastics. However, this material combines the optical properties of regular plastic along with greater impact resistance. It is the lightest weight of any lens material available, blocks UV radiation, comes with a hard coating for surface protection and is ideal for drilled rimless and groove mounted frames.

Positive Points	Negative Points
<ul style="list-style-type: none"> <li>• Lightest weight material available</li> </ul>	<ul style="list-style-type: none"> <li>• Not as thin as high-index materials</li> </ul>
<ul style="list-style-type: none"> <li>• Thinner than regular plastic</li> </ul>	
<ul style="list-style-type: none"> <li>• Ideal for drilled rimless</li> </ul>	
<ul style="list-style-type: none"> <li>• Increased impact resistance</li> </ul>	

## Polycarbonate

During the 1980s, polycarbonate became a popular choice for ophthalmic lenses due to its light weight, thinness, superior impact resistance and UV protection. As the most impact-resistant material for lenses, polycarbonate should be recommended for children, young adults, and others with active lifestyles as well as for safety eyewear. Polycarbonate lenses can be up to 30 percent thinner than regular glass or plastic lenses and provide protection from harmful UV rays by filtering the radiation in the UVA and UVB areas. Scratch resistant coatings must be applied to protect the surfaces.

Positive Points	Negative Points
<ul style="list-style-type: none"> <li>• Superior impact resistance</li> </ul>	<ul style="list-style-type: none"> <li>• Can be hard to tint</li> </ul>
<ul style="list-style-type: none"> <li>• Blocks UV radiation</li> </ul>	
<ul style="list-style-type: none"> <li>• Thinner lens</li> </ul>	
<ul style="list-style-type: none"> <li>• Hard coating for surface protection.</li> </ul>	
<ul style="list-style-type: none"> <li>• Suitable for drilled rimless</li> </ul>	

## High Index Plastics

High index plastics have a higher index of refraction. The benefit to the patient is a thinner, lighter lens compared to lower index materials. High index materials are available in indices of 1.60, 1.67, 1.70, and 1.74. High index plastics provide a benefit in reduction of thickness and weight, especially for the high-power prescriptions. Your lab partner can help you determine the best choice of high index plastic to meet your patients' needs.

Positive Points	Negative Points
<ul style="list-style-type: none"> <li>• Thinnest lens material</li> </ul>	<ul style="list-style-type: none"> <li>• Not available in all lens styles</li> </ul>
<ul style="list-style-type: none"> <li>• UV protection</li> </ul>	<ul style="list-style-type: none"> <li>• Some are not suitable for drilled rimless</li> </ul>

## Glass

For many years glass was the material most widely used for eyewear lenses, but in the 1970s other materials started capturing large sections of the lens market. Glass still provides excellent optical quality and a very scratch resistant surface. But glass is twice the weight of comparable plastic materials. Glass lenses must be treated to comply with FDA impact resistance requirements.

Glass lenses can be coated in color tints or they can be mirror-coated. Tinted glass lenses are produced by adding metal oxides during the manufacturing process.

Positive Points	Negative Points
<ul style="list-style-type: none"> <li>• Superior scratch resistance</li> </ul>	<ul style="list-style-type: none"> <li>• Heaviest material</li> </ul>
<ul style="list-style-type: none"> <li>• Excellent optics</li> </ul>	<ul style="list-style-type: none"> <li>• Not advised for drilled rimless</li> </ul>
<ul style="list-style-type: none"> <li>• No ledge for multifocal segments</li> </ul>	

## High Index Glass

High index glass lenses are available in some styles. These lenses provide a thinner lens than comparable regular glass but are much heavier due to the higher density of the material. As an example, regular glass has a density of 2.54 g/cc compared to 1.80 high index glass with a density of 3.37 g/cc. As the index of refraction increases, the density or weight increases, resulting in a heavier lens for the patient.

Positive Points	Negative Points
<ul style="list-style-type: none"> <li>• Thinner than regular glass</li> </ul>	<ul style="list-style-type: none"> <li>• Heavier than regular glass</li> </ul>

*Note: Check with your laboratory for lens availability and Rx restrictions.*

## Other Materials and Questions

The materials mentioned above are not the only materials available. Consult your lab partner for additional recommendations. Remember, you can enhance the cosmetic and visual performance of eyewear by recommending A/R (Anti-Reflective) treatments, mirror coatings or UV treatments. Such enhancements are considered part of the overall lens package.

## Styles

Basic lens styles are designed by the manufacturer to meet the vision needs of the patient. The final lens selection process should take into consideration the style, design, lens material and enhancements.

### Single vision lenses

The single vision lens provides vision correction for one viewing area. The corrected area can be for far distance, near distance or reading. The prescription can be written for spherical correction, with the same power in all directions, or for correcting astigmatism with a spherical correction combined with a cylinder power amount to create two lens powers 90 degrees apart at a specified axis (direction).

Example:

Sphere Power Prescription  
+ 1.00 sphere

Astigmatism Power Prescription  
+1.00 - 0.50 x 90

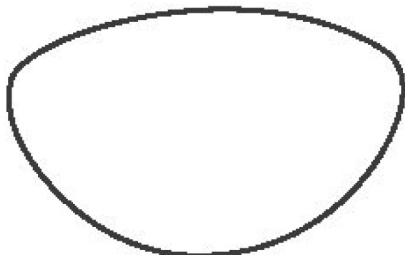

*Single-Vision Lens*

### Aspheric Designs

Traditional single vision lenses incorporate spherical curves on the front side (convex) which means they have the same radius of curvature over the entire front side, like a round basketball. In higher plus powers (+2.00D and up) lenses, wearers looking at objects off the center of the lens may experience a “pin cushion” effect or a distortion of images. Plus power lenses will make the eyes of the wearer appear magnified and larger than normal to the person looking at the wearer. Finally, higher plus powers will produce thicker lenses in the center. The front curvature of an aspheric design lens changes gradually from the center of

the lens towards the outer edges. The benefits of the aspheric design include improved peripheral images, less magnification of the wearer’s eyes and a thinner lens in the middle. These benefits generally apply to plus power lenses only.

### Atoric, Bi-toric or Bi-aspheric Designs

Like aspheric design lenses, an atoric lens has an aspheric design in which both meridians are aspherized. The curves on the back of a conventional lens produce both sphere and cylinder (compound lens) correction. The atoric design will also address optical corrections in all meridians of the compound lens. In minus prescriptions an atoric design will help to reduce lens edge thickness, improve peripheral images and reduce the minified appearance of the eye as compared to traditional design lenses.

### Progressive Lenses (PALs)

Progressive lenses are sometimes called no-line or invisible bifocals. The Progressive Addition Lens (PAL) is designed with no lines to allow the presbyopic patient to see at distance, intermediate and near. This is accomplished by changing front surface curves of the lens both vertically and horizontally to provide a wide range of foci from distance to near vision. It also creates the additional power needed for near viewing, all with no sudden interruption in vision which is a common complaint of bifocals. Different manufacturers offer a variety of approaches in their designs but for the first 35 or 40 years that they were available, all PALs were manufactured and fabricated in the same way or what we now term as conventional technology.

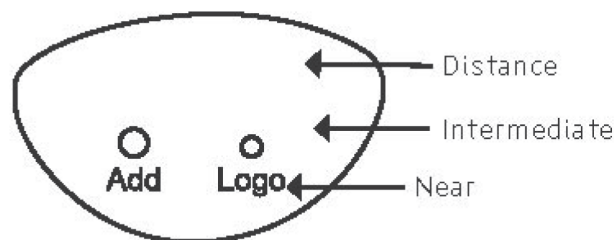

*Progressive Lens*

## Conventional PAL Design

For the last four decades of the 20th century, the front surface curvatures that comprise the progressive lens designs were molded by the manufacturer on to the front surface of a semifinished lens blank. The lab chooses the lens blanks according to its base curve, add power and material to process the order. The back side of the blank is then surfaced, or ground down by using hard “lap” tools which produce the required sphere and cylinder powers. Because there can only be one design applied to the front surface of each base curve or add power lens blank, there is a limit to how much the design can be optimized for each patient’s prescription and individual performance needs.

Developments in lens designing and mold fabrication allowed manufacturers to apply more complex curves on the front side of the lens blank. Still, using the same surfacing tools that grind the back side sphere and cylinder powers onto the lens blank limit how well the design can deliver optimal visual performance. The solution to overcome the drawbacks of the conventional progressive lens performance with conventional surface tooling was in the advent of free-form lens designing and digital surfacing technologies.

## Free Form Lens Design and Digital Surfacing

Thanks to the digital generating capabilities in the lab, lens designs can be tailored to the wearer’s prescription, frame and even lifestyle requirements.

More personalized measurement information taken at the time of fitting the glasses can be collected and entered into the lens design software to further enhance the wearer’s vision. Those measurements are referred to as the *position of wear*; vertex distance, facial wrap and pantoscopic tilt. See Measurements for Free Form PAL designs, page 26.

Even a conventional progressive with the design molded on the front surface of a SF blank, can be surfaced using a digital generator. Although not a free form design, this process may deliver better optical results than the conventional surfacing method.

Whether the lens is designed conventionally or personalized, there are considerations that must be made with the use of a PAL. One of those is the size of the frame into which the lens will be edged and mounted. Smaller frames require a different approach than larger frames. To accommodate the smaller frames, where the minimum fitting height could be as low as 14 mm or less, a “short corridor” design will be employed. Most digital lens designs automatically choose the best corridor length based on the fitting measurements.

All progressive lenses are identified by finding the manufacturer-engraved symbols located in the nasal area of the lens and the add power, located in the temporal area of the lens. Using The Vision Council’s EPIC (Electronic Progressive Lens Identifier) as a reference, you can identify the manufacturer, brand, add power and material of most progressive lenses on the market.

## Bifocals

Bifocal lenses are designed with two different viewing areas, one for distance and one for near viewing. The distance area is designed like a single vision lens, while the near area contains the distance prescription and the additional amount of plus spherical power needed to see at a reading distance of approximately 12–14 inches. The additional amount of plus power (also called the add power), for reading is located in an area referred to as the segment or seg. Segment shapes can be round, straight top, or a straight line across the lower half of the lens.

Sometimes the same bifocal style can be called by different names. The bifocal pictured can be called a Straight Top, Flat Top or D Seg. The bifocal segment size is measured at the widest point and is referenced in millimeters (mm), i.e., ST28.

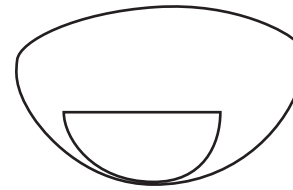

*Bifocal lens*

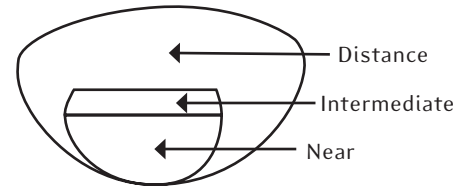

*Trifocal lens*

## Trifocals

The trifocal lens is an extension of the bifocal lens. As the need for add power increases during advancing presbyopia, the view area for near vision becomes shorter and shorter. Eventually, the bifocal lens can only provide vision correction for distance and close-up near viewing, leaving the intermediate area between distance and reading uncorrected. The trifocal lens provides another segment on the lens above the reading viewing area to correct the intermediate viewing area between distance and near. The intermediate segment power is usually 50 percent of the add power, except for trifocals designed for computer use in an office. Computer trifocal lenses will have an intermediate percentage of the add power in the low 60s.

Trifocals are identified by name, intermediate height and widest segment width. For example, a “7 x 28” is a trifocal lens that is 7mm high in the intermediate and 28mm wide.

## Occupational, Task-Specific or Variable Focus Lenses

Many patients work in an environment that requires vision only within intermediate and near distances. The time spent in this environment can be for a few hours to all day so specific lenses provide a tremendous benefit to the patients working in this environment. These are also commonly referred to as computer lenses but this term may limit the application of these lenses to just computer users when there are lots of situations where they will work well.

The simplest would be single vision lenses with a lens power prescribed to give the most comfortable vision at the wearer’s most critical working distance.

Another solution may include occupational bifocal and trifocal lenses. These can be customized for the particular vision needs. A prescription can be written to correct for the appropriate intermediate and near distance requirements.

There are also special progressive lens designs that provide correction for near, intermediate and in certain styles, distance vision. They have a larger intermediate zone than conventional progressives for more comfortable vision at the task they are intended for. Some of these lenses use a *digressive* design where the powers digress from the near point of the lens up to distance. The patient will enjoy wide areas of intermediate and near vision, however the powers you read on the lenses may not be the powers you were expecting.

Because these lenses are prescribed for a specific use, they are not suitable for driving or general purpose wear. The use of tints, UV blocking and antireflective treatments should be recommended to enhance the performance of the lens. Ask your lab partner for more information about these particular designs.

## Specialty Lenses

Specialty lenses are available to meet specific vision needs, lifestyle applications or recreational and hobby needs. These lenses are designed with a special segment size and shape, and powers for specific distances such as for a golf lens. Some have special colors for certain vision use, for example, specially tinted hunting lens. Some lenses are designed to meet the needs of patients needing extremely high power prescriptions, i.e., cataract lenses. Consult your lab partner for additional recommendations.

## Lens Enhancements

### Scratch Resistant Treatment (S/R)

When plastic lenses emerged in the 70s as a major lens material, one disadvantage was their soft surface, which scratched more easily than glass lenses. Since then, a scratch resistant treatment has been developed for use on plastic lenses, that significantly reduces scratching.

Even with a scratch resistant (S/R) treatment on their lenses, patients should always be told that no material is scratch proof. All lenses can be scratched, even glass.

Lenses are available from the manufacturer with S/R treatment on both sides. Lenses are also available from the manufacturer with a front side only S/R treatment. The back side of the lens can then be treated by the laboratory during the processing of the prescription.

Today's S/R treatments are better than ever. They are durable and have excellent adhesion to the lens surface. For some lens styles, a super-hard S/R treatment is available but these lenses cannot be tinted.

### Anti-Reflection Treatment (A/R)

Eight percent of light is lost as it passes through a clear glass or plastic lens. The percentage of loss actually increases with high index material to as much as 12 to 16 percent. Where does the light go? The reduction of light transmission is due to both external and internal reflections that occur as light passes through the lens.

External reflections are annoying to the patient and are not cosmetically pleasing. From the front side, external reflections have a mirror effect, which hides the eyes and is noticeable to others. Patients also complain about back surface reflection when they mention "seeing their eyes" or seeing side reflections off the back lens surface. Internal reflections can create secondary images of objects. This is especially noticeable when looking at bright lights



in the dark. Anti-reflection (A/R) treatment provides important benefits to the patient by almost eliminating both of these annoying reflections. A/R treatment is applied to both lens surfaces in multiple layers, increasing transmission in regular glass or plastic lenses to 99 percent or above. Because high index lenses have flatter curvatures than lower index lenses of the same power, high index lenses reflect more light. With an A/R treatment light transmission on higher index lenses will increase to 99% or better. A/R treatments are increasingly popular due to availability, better demonstration materials, and patient satisfaction with their performance.

Newer premium A/R treatments will usually include a hydro-phobic and olio-phobic finish over the A/R to help repel water, finger prints, smudges and oils. This is sometimes referred to as a “slippery coat” and helps to make the lenses easier to clean and stay cleaner, longer.

## Ultraviolet (UV) Protection Treatment

Most consumers are aware of the harmful effects of long-term exposure to ultraviolet radiation (sun exposure) on the skin, but some people may be unaware that eyes also need protection from the sun.

Regular glass or plastic lenses must be treated to provide UV protection. Plastic lenses can be dip-coated, and glass lenses color-coated, to provide UV protection. Most mid- and all high-index materials provide protection due to the chemistry of the lens material. Photochromic lenses also provide protection.

The UV radiation area of the spectrum is divided into three sections, UVC, UVB and UVA. UVC radiation is blocked by the ozone layer and does not affect humans. UVB and UVA radiation, however, can cause eye damage, so protection is necessary to block ultraviolet radiation. For lens materials that do not provide UV protection, the cost can be included in the lens price to provide this important benefit.

## Filters / Tints

A common application to any lens surface is a color filter/tint. Plastic lens filters/tints are usually applied at the lab during processing while glass lens filters/tints are applied using a vacuum deposition process or during the manufacturing process. In fixed tints, the color of the lens remains the same for the life of the lens.

Current fashion style, sun protection, recreational activity and hobbies are just some of the reasons to recommend lens filters. Shades of the colors can be represented in various ways. For example, gray shades can be represented by letter or number, as shown below.

Light to Dark				
	Lens	Lens	Lens	
Gray	1	2	3	By number
Gray	A	B	C	By letter

Lens filters reduce light transmission in the visible area (380nm to 760nm). The reduction in transmission can be in specific areas or overall depending on the shade, color, and material.

Solid filters/tints are uniform in color across the lens while glass tints may vary in shade due to the thickness of the lens. Gradient filters/tints change from the edge of the lens (dark) to the center (light). This gradual change can take place from the top, bottom or from both the top and bottom of the lens.

Filters/tints should be chosen according to the specifications in the tint book from your laboratory. Sometimes it is necessary to send a sample of the requested filter/tint to the laboratory.

Be aware that sample filters/tints can fade over time. Replace them when necessary.

Glass or plastic lenses that get darker in color as they are exposed to sunlight are called photochromic lenses (see “Photochromic Lenses”).



# EYEWEAR SELECTION

## Lifestyle Considerations

When the patient arrives in the dispensing area the task at hand for the dispenser is to convert the Rx into a laboratory order that will provide the necessary information to complete the finished eyewear product. This process can be a rewarding experience for both you and the patient, and will result in a product that will meet the visual, cosmetic and lifestyle needs of the patient. The key to success in this process is understanding the features and benefits of your products, good presentation skills and applying this to the lifestyle needs of your patient.

Lifestyle needs include occupation, recreation and general life activities. You will want to identify any concerns and the patient's likes and dislikes about eyewear in general.

The above information can be gathered in different ways and at different times during the patient's visit to your office. Some offices start the process as soon as patients arrive by having them fill out a lifestyle questionnaire. Lifestyle questionnaires will gather information about the patient's profession or occupation, recreational activities, leisure or special interests and current eyewear information.

The Vision Council has developed the "Clear Choices – YOUR Eyes, YOUR Lenses, YOUR Choices" brochure, which has been used in professional offices to introduce patients to lens products and enhancements that meet a variety of visual and cosmetic needs. The brochure creates patient awareness of lens enhancements such as anti-reflection (A/R) treatments and the need for ultraviolet (UV) protection; it serves not only as an information item but can be used by the patient for future reference.

It is best to gather lifestyle information at the beginning of the patient's visit to allow the doctor to make lens recommendations during the exam. Lifestyle questions should relate to hobbies, dress, occupation and special needs of the patient. Having this information helps you and the patient through the eyewear selection process.

First impressions are important. In those first few seconds the patient will form his or her opinion of you as a dispenser. Make it a good one. Welcome them into the dispensing area. Look them in the eyes as you greet them. Be cheerful and professional. As you gather lifestyle information ask open-ended questions starting with "What," "Why" or "How." For example, "How much time do you spend at a computer each day?" Their answers are a treasure chest of information for you to use.

## Rx Evaluation

Once you obtain the necessary lifestyle information, the process of selecting lenses and frames begins. It is recommended to first select the lenses, then the frames. The lenses are the most important part of eyewear as they fulfill the objective of providing better vision. With today's premium lens products and lens enhancements, you have the ability to solve vision concerns and enhance the appearance and performance of the lenses. Before making a lens recommendation, evaluate the new prescription, keeping lifestyle information in mind.

Is the prescription plus power or minus power? Is the power amount low, such as plus or minus 1.00 diopter, or high, such as plus or minus 4.50 diopters? As power increases so does lens thickness. Plus lenses become thicker in the center and minus lenses thicker at the edge as power increases. The final size of the lenses also contributes to the thickness of the lens. When larger frames are chosen the thickness for plus and minus lenses will also increase. Patients with astigmatism require two different powers in their lenses. This will cause the appearance of the lens edge thickness to be different 90 degrees apart. The difference in edge thickness is determined by the cylinder amount of the prescription (+2.00 – 1.00 x 90, -1.00 is the cylinder amount). The greater the cylinder amount of the prescription, the greater the edge thickness difference.

## Presentation Process

The presentation process is your opportunity to provide information about the lens product. To be



# FACIAL MEASUREMENTS AND FRAME SELECTION

## Facial Measurements

Knowing the correct powers for each lens is not enough to ensure vision correction. The lenses also must be aligned properly in front of the eyes and the frame holding the lenses also must be comfortable to the patient. It is important to have the correct facial measurements to properly align the eyewear. Often times, when a patient returns with visual complaints of their new glasses, the culprit can be poor measurements and positioning of the lenses in front of the eyes. Be careful with all the measurements as it can go a long way towards preventing complaints after the glasses have been dispensed.

## PD Measurements

The distance from the center of the pupil in the right eye to the center of the pupil in the left eye is called the inter pupillary distance, or PD for short. This measurement can be taken for distance viewing when the lines of sight for the eyes are parallel looking at a distant object (Far PD), and can also be taken for reading at near distance (Near PD). The near PD measurement will be shorter than the distance PD measurement by 2 to 5mm because the eyes turn in, or converge, at near distance.

Use a Corneal Reflection Pupilometer (CRP) to measure PDs. The CRP method is an accurate and consistent way to measure the PD because the CRP uses the corneal reflection of the eye (a dot of light on the pupil) as a reference point for the measurement. It provides both a monocular reading (center bridge to right and left eye) and binocular readings (right eye to left eye) at the same time. Monocular readings are needed to accurately place the optical characteristics for lenses such as progressive addition lenses. The PD can be measured using a millimeter ruler but only as a last resort.

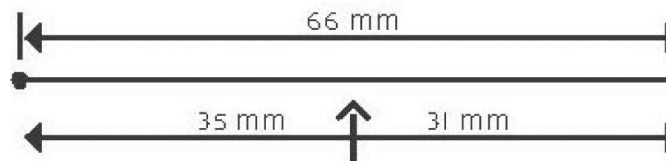
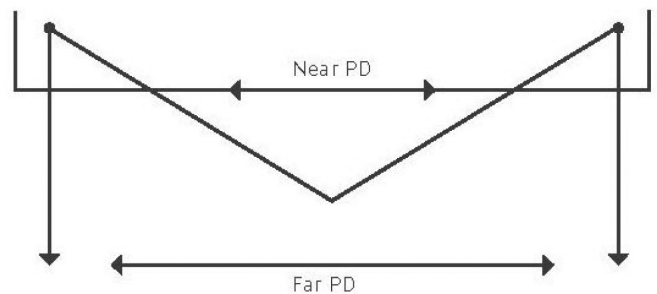

## Fitting Height Measurements

Fitting height measurements are taken to determine bifocal, trifocal, or progressive height. This measurement is taken from the lowest part of the eyewire to the guideline. The guideline for a bifocal is the lower lid, for a trifocal it is the lower edge of the pupil, and for progressive addition lenses it is the center of the pupil.

Depending on specific circumstances, the final fitting height measurement might be more, less, or the same as the guideline measurements. Factors that may affect the final fitting height measurements are:

1. The amount of use at the near viewing area;
2. The customer's posture;
3. The pantoscopic angle;
4. How far the lenses will sit from the face;
5. The prescription; and
6. The previous segment location.

When taking a fitting height measurement, you must:

1. Adjust the frame before measuring;
2. Sit at eye level with the patient;
3. Measure to the deepest part of the frame; and
4. Double-check your measurement.

Follow the fitting height recommendations of the manufacturer. As with measuring PDs, fitting height measurements can be taken different ways. You can use either a millimeter ruler or mark the lenses. Marking the lenses is preferred because it allows you to observe the marking position on both eyes at the same time.

When you are measuring for an aspheric single vision lens, you should also take an optical center height measurement. This is the vertical distance from the lowest portion of the eyewire to the center of the pupil, minus

2 mm. This will position the aspheric lens perfectly in front of the eyes in a well adjusted frame.

## Measurements for Free Form PAL Designs; Position of Wear

With the sophistication of free form progressive lenses, there is also the ability to further refine that design to be optimized for the way it will be positioned in front of the face once it is mounted in the frame. This adds yet another set of measurements, called Position of Wear or sometimes called "As Worn", that can be taken and submitted with the order. Once the frame is selected, it must be adjusted to the wearer as if they were going to wear it out the door before the measurements are taken. Those measurements are;

- Vertex distance; the distance, in millimeters, from the back surface of the spectacle lens to the apex (front) of the cornea. This can be measured with a digital measuring device or a distometer.
- Facial wrap or wrap angle; the amount of curvature of the frame front, in degrees, relative to the horizontal plane of the face. This can be measured with a digital measuring device or a protractor or protractor-like device.
- Pantoscopic tilt; the amount of inclination, in degrees, relative to the vertical plane of the face. This can also be measured with a digital measuring device or a protractor.

To aid the dispenser in precisely capturing the measurements, lens manufacturers have developed digital measuring devices. These devices may also serve as an aid in showing pictures of the patient wearing the frames and as well as a virtual demonstration of lens features like A/R, photochromics, polarized and high index lenses.

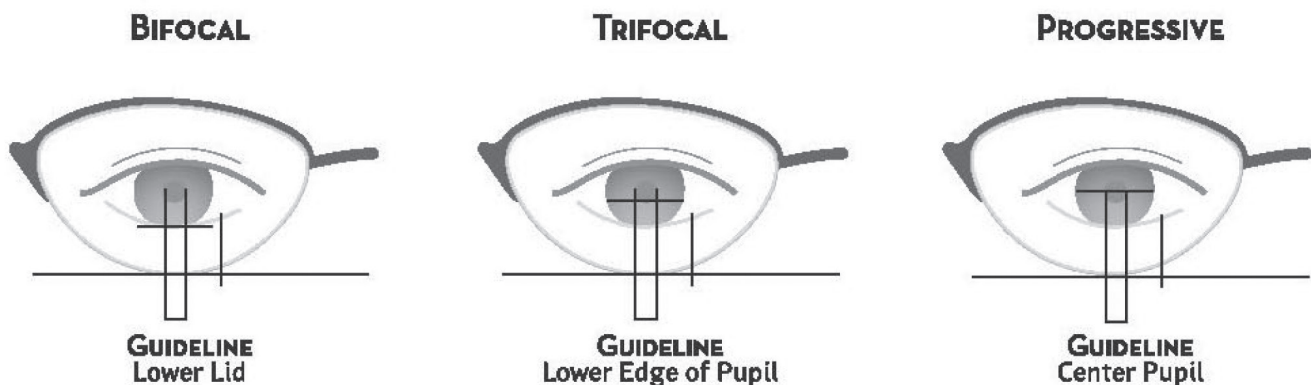

# Frame Selection

## Frame Measurements

The two basic parts of a frame are the front and temples. The front consists of the bridge and two eyewires. There are two common dimensions that relate to the front, the eyesize and the bridge. Both of these dimensions are determined by a system that was developed to help standardize the way frames are measured. It is called the boxing system. The eyesize is referred to as the "A dimension." It is the widest horizontal dimension. The bridge size is referred to as the DBL (shortest distance between lenses).

These dimensions, the eyesize and DBL, are measured in millimeters. Another important dimension of the front is the ED (effective diameter). This dimension is used to determine the size of the lens necessary to complete the Rx to the required specifications. The ED is determined by measuring the longest radius and multiplying that number by two.

The B dimension is the longest vertical dimension of the eyesize. This dimension is used to locate the vertical height dimensions and is measured from the top of the lens to the lowest part of the lens.

An important reference point that is determined in relationship to the front of the frame is the geometric center (GC). This point is determined by connecting opposite corners of the box around the lens with a diagonal line. The point of crossing in the center is the GC. The GC for each eyewire is used to determine the DBC (distance between centers). This is the horizontal dimension of the frame, sometimes called the frame PD.

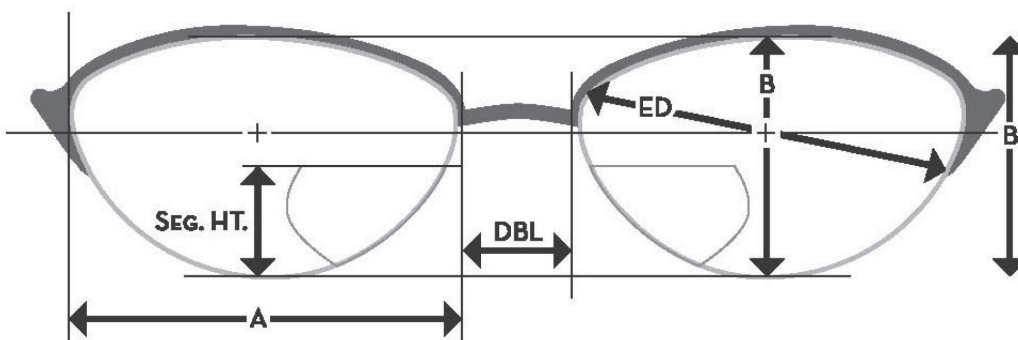
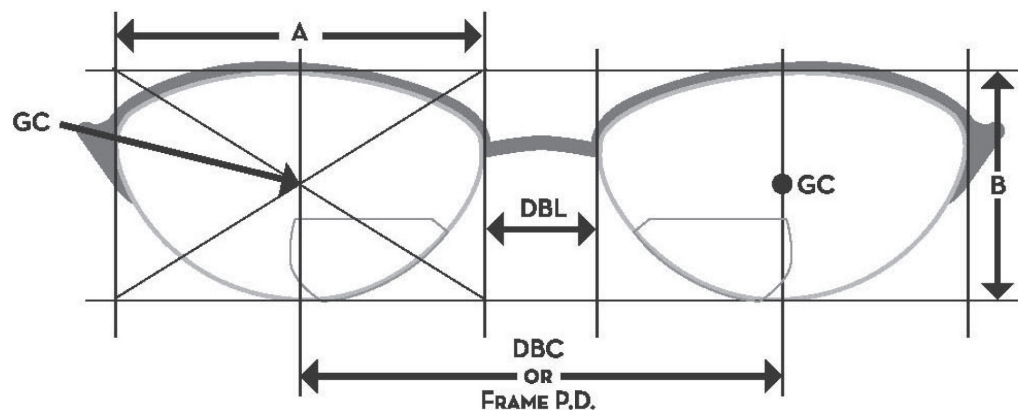

## Review: Measurements

Let's review the measurements we've discussed.

**A dimension:** Widest horizontal measurement of the eyewire; it is sometimes called the eyesize.

**DBL:** Shortest distance between the lenses.

**ED:** Effective diameter; it is equal to 2 times the longest radius of a lens.

**B dimension:** Widest vertical measurement of the eyewire.

**GC:** Geometric Center: Located at the intersection of the diagonals of a box frame front.

**DBC:** Distance between the geometric centers of the eyewires (GC).

## Decentration – Frame Size vs. Patient's PD

In most cases, the frame DBC measurement is not the same as the patient's PD. Their line of sight (PD) is not at the geometrical center of the frame but is usually located in from the GC of the frame toward the nose. To place the optical center of the lens to coincide with the patient's PD, the laboratory will need to grind or move the optical center the distance in millimeters from the GC of the frame to the line of sight. This distance is referred to as decentration. The greater the difference between the frame DBC measurement and the patient's PD, the larger the decentration amount will be. Decentration affects lens thickness by increasing the temporal edge thickness of minus lenses, and increasing the center thickness and nasal edge thickness of plus lenses. To avoid the additional thickness, guide the patient to a frame that has a DBC measurement close to the patient's PD measurement.

## Frame Materials and Styles

### Frame Materials

Today's frames are made of many different types of materials depending on the required style, durability, color, and ease of use. For the most part, though, frames are made from plastic and metal.

Plastic frames are available in many colors and are usually thicker and wider than metal frames. Metal frames tend to be thinner, lighter-weight, and more durable. Each material has features that make it popular.

### Plastic

There are a variety of plastic materials available for eyewear today. Though they're similar, they sometimes require different handling procedures. Some plastic materials require low heat, while others require no heat or high heat when adjusting the frame. You should follow the manufacturer's recommendations to avoid damaging the frame.

### Cellulose Acetate

Often called "Zyl," this frame material is widely used for today's frames. Its characteristics include:

- Metal core in the temple
- Easy to heat and adjust
- Widely available

To adjust a cellulose acetate frame, heat the frame using a heating box filled with plain salt or glass beads. A hot-air warmer can also be used.

### Propionate

A lightweight frame material available in vivid colors, propionate is:

- Lightweight
- Hypoallergenic
- Available in a variety of designs due to the manufacturing process

Use low heat to adjust propionate frames. A hot-air blower is recommended.



## Nylon

Nylon is a durable frame material often used for sports frames and goggles. It is:

- Lightweight
- A molded material
- Available in limited colors

Nylon is difficult to adjust and hold the adjustment shape. A heating box can be used to heat the frame.

## Metals

Different alloys are used to create metal frames. Today's metal frames are thin, lightweight and often used in rimless frames. Excessive bending of any metal frame can weaken it, so when adjusting, remember to brace the frame at the area of the adjustment.

## Titanium

A popular metal material that is lightweight and durable, titanium is:

- Strong
- Hypoallergenic

## Stainless Steel

Stainless steel is made of iron and chrome and is:

- Durable
- Lightweight with a thin profile

## Monel

A widely used alloy for metal frames, monel is:

- Strong
- Lightweight
- Easy to work with

## Frame Selection for Cosmetics and Fit

Frames are designed in different styles for fit and cosmetic appeal. Each frame consists of the front, which has two eyewires (right and left eye) and the bridge area, which rests on the nose. Attached to the front are two temples, which are available in different styles. The attachment area of the front and temple is often called the endpiece.

### Full Frames

Full frames consist of two eyewires that go around the entire circumference of the lens. These are made of metal, plastics or a combination of materials.

### Drilled Rimless Frames

The lenses in a drilled rimless frame are held in place with bridge and endpiece mountings. The lenses are attached to the mounting with holes drilled through the lenses. This type of frame is sometimes called a three-piece mounting. Be careful when adjusting this frame to avoid lens breakage. Rimless lenses should be braced at the point of attachment to the lens before adjusting. Special hand tools are available to help accomplish this. Use recommended lens materials to avoid chipping and cracking the lens around the drill hole. Avoid using rimless frames for high power prescriptions. Discuss the best lens designs and materials with your lab partner.

### Grooved Rimless Frame

A partial eyewire extends around a semi-rimless frame, holding the lens in place with a nylon string or thin metal wire around the circumference of the lens. The lens edge is grooved to hold the string/wire in place.

### Combination Frame

Combination frames combine a metal chassis to hold the lens, two trim end-pieces attached to the chassis and two temples attached to the endpieces. The endpieces and temples can be plastic or metal.

## Half-Eye Frame

The lens area for a half-eye frame is designed with a small reading lens to allow the patient to look over the frame top for distance viewing.

## Sports Frames

Specifically designed for sports activities, these frames can be made from different materials and must have high impact resistant lenses for maximum protection. When selling frames for sport activities, be sure they meet the appropriate ASTM standard for that sport.

## Wrap Frames

One of the more popular styles of sunglasses is known as a wrap. This style follows the contour of the face with a high degree of curvature in the frame. While these are stylish and practical, they can represent a challenge for lens designers, labs and dispensers. The front and back curves of spectacle lenses are specifically used to conform to the best optics in a narrow range of prescription powers. When the frame chosen requires a substantially different curvature of lens to fit well in the frame – and to be cosmetically pleasing – the visual performance for the wearer will suffer. Fortunately, modern lens design software can design a solution for a large majority of prescriptions without compromising vision. Called Rx Wrap Compensation,

this software will calculate what powers need to be ground into the lens in order to give the wearer the kind of vision the written prescription intended and in a curvature of lens that will fit into the frame. Often, the powers that you read through this lens in the lensometer will not be exactly the same as the prescription called for. Initially the patient may have to make a slight adjustment when changing from regular glasses to the wrap glasses. This is normal and you should tell them to expect this. Call your lab partner before the frame is chosen to find out what prescription limitations there are when considering a wrap frame for your patient before the frame is chosen.

## Safety Frames

Safety frames must meet the requirements of the most current ANSI Z87.1 standard. Safety frames for prescription lenses must have the mark of the manufacturer and Z87-2 on both temples and the front.

## Bridge Types

There are several ways to rest the front of the frames on the nose. Adjustable rocking nose pads may be attached to the bridge. A special bridge insert of molded plastic, sometimes known as a form-fit bridge, may also be used. Or, the bridge and nose rest area may be integrally molded into the frame. The latter technique is used for most plastic frames. The bridge in plastic frames may be further classified into the keyhole bridge and the saddle-style bridge.

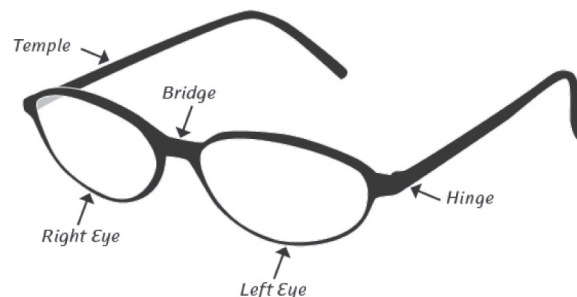

A Frame with a Saddle Bridge



A Frame with a Keyhole Bridge

## The Temple

The temple of the frame is the long portion that supports the frame on the ears. It is also known as the earpiece.

There are a variety of different styles of temples. The three basic types of temples used on eyeglasses are illustrated on this page.

*Note: The overall length that you will find marked on the temple is actually the unbent length.*

### Library Temple

The library temple was more common years ago. However, you may occasionally see one. It was designed to make the eyewear easy to take off. It is necessary to have additional pressure placed on the head by the temple to compensate for the lack of temple bend.

### Skull Temple

The skull temple is the most popular temple style. The temple end is bent approximately 1-1/4 inches from the end down around the ear.

### Riding Bow Temple

Usually used for smaller children's frames to better hold the front in place, riding bow temples are made of plastic with the back half designed like a tube of plastic around a metal core.

### Comfort Cable

Comfort cable temples are designed so the front half of the temple can be plastic or metal with the back half made of flexed cable. As with the riding bow temple, this style holds the front in place.

### Measuring Temple Length

Temple length is now measured in millimeters, but used to be measured in inches. Therefore, you may occasionally have to convert a measure from inches to millimeters. At right is a conversion scale which can help in your calculations.

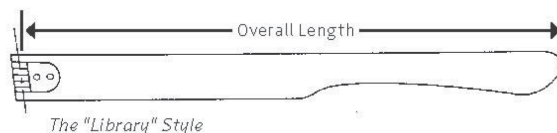

*The "Library" Style*

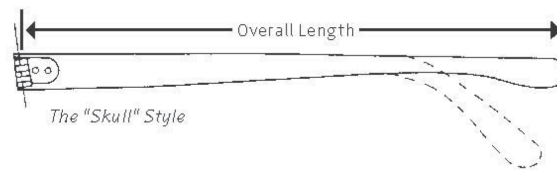

*The "Skull" Style*

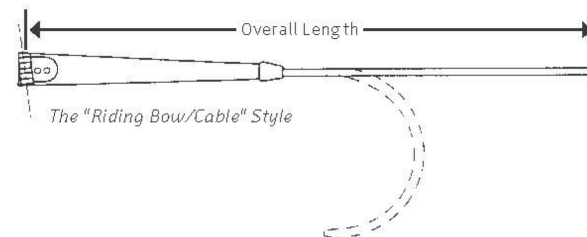

*The "Riding Bow/Cable" Style*

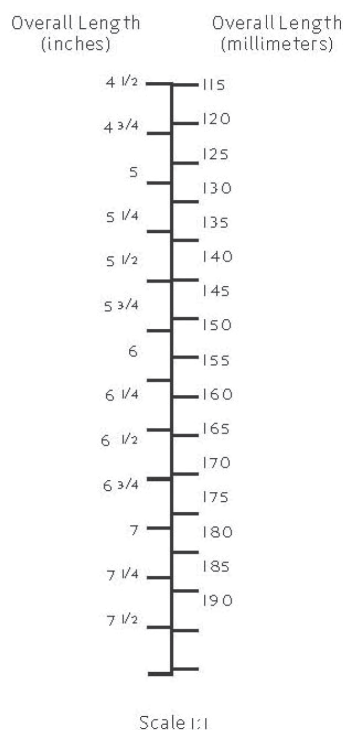

## Frame Selection

To arrive at the proper frame selection for your patient you have to meet the goal of providing the best frame for cosmetic consideration and comfort, as well as the best lens appearance. Since the lens selection will directly affect appearance and performance, the lens choice should be determined before choosing a frame.

When selecting frames for the patient to try on, choose frames that will fit for correct size and sitting position on the face. It is necessary to select frames with the correct frame measurement, which includes the correct eyesize and bridge. Also, the temple must be long enough to allow for proper temple bend to create the friction necessary to hold the eyewear on the face.

Here are some general guidelines to follow when you are showing frames to your patients:

1. The frame–front width should be approximately the width of the patient’s head.
2. Eyes should be positioned in the central part of the frame–front eyewire.
3. For plastic frames, the bridge shape should contour to the nose shape.
4. Adjustable pads should provide even pad contact on the nose.
5. The temple length should allow a temple bend length of 1 to 1-1/4 inches.

Frame cosmetics include frame shape and design. Today, the wide variety of frame colors even includes frames that seem to change color depending on how light strikes them. When guiding the frame color selection, consider how the frame color compliments the patient’s hair, eyes and skin tone.

Face shapes should also be considered, with frame shapes selected to balance facial characteristics. A face shape can be square, round, triangular, oblong or oval. The key to determining the face shape is usually the patient’s chin. The oval face is considered to be the shape that can cosmetically wear all frame shapes.

The other face shapes are balanced by selecting frame shapes that are considered opposite that of the face shape.

Frame design, which is driven by fashion trends, is usually a high priority in the patient’s selection process. Design does not always coincide with the best visual performance or lens appearance. As an example, years ago large frames, which required thicker, heavier lenses, were the trend.

The recent trend to smaller frames has meant thinner, lighter lenses. The dispenser must make sure the smaller lens size will accommodate all the necessary optical characteristics, such as enough space for the reading area, when using progressive addition lenses.

As your patients goes through the selection process, you should explain to them how the frame selection contributes to the overall cosmetic effect. Patients will appreciate your input. The time to address any issues is before the Rx is ordered. Guiding your patient to the proper selection will mean fewer adjustments later on.

## Optical Performance

Lenses are designed to provide the best visual performance, cosmetic appearance and comfort. Taking accurate facial measurements and helping patients select the correct lenses and frame will assure your patient’s satisfaction with their vision and appearance.

# FROM RX TO EYEWEAR

## The Doctor's Prescription

The doctor's prescription, or Rx, is the window to your patient's visual needs. Though the numbers and letters on the form are only a small part of the overall vision examination, the information on the prescription, combined with your knowledge, will allow you to guide the customer in the proper selection of frames and lenses.

The major areas of the prescription form are:

- ① Patient's name and address
- ② Date of eye exam
- ③ Distance vision prescription for right eye
- ④ Distance vision prescription for left eye
- ⑤ Near Vision, Add Power for right and left eyes
- ⑥ Remarks – additional information
- ⑦ The doctor's signature

Additional areas may be printed on the form to meet the needs of your office.

In the dispensing area, two major decisions will be finalized: the selection of lenses and the selection of frame(s). Eyecare providers tend to agree it is best to determine the lens selection first, then the frame selection. Choosing the lenses before the frame allows you to educate the customer on the different types of lenses and lens enhancements available, then determine which frames can accommodate the lenses chosen.

Often the patient has not considered the lenses or their cost. If the frame is selected first, the patient may be inclined to settle for lenses that are less than what is recommended, which can result in reduced visual performance and lens cosmetics and, ultimately, a dissatisfied customer.

Many offices use the marketing concept of eyewear bundling or packaging. This concept presents the customer with the best lens options at a value price.

FOR _____ ①		DATE _____ ②				
ADDRESS _____ ①						
	R <sub>x</sub>	SPHERICAL	CYLINDRICAL	AXIS	PRISM	BASE
D.V.	O.D.	③				
	O.S.	④				
N.V.	O.D.	⑤				
	O.S.	⑤				
REMARKS _____ ⑥						
		DR. _____ ⑦				

# The Laboratory Order

Once you have finished the selection process, the laboratory order to produce the eyewear must be completed. The accuracy of the laboratory order is critical to the completion of the eyewear.

Before the patient leaves the dispensing area, make sure you have all the information necessary to order the eyewear from the laboratory. Double-checking now will prevent an embarrassing call later to ask the patient to return to the office so you can complete or correct the necessary information.

Many offices now use a computer to directly place the order, via internet connection directly with the processing lab. This is the preferred method because the ordering software is very user-friendly and

avoids many of the common, frustrating and time-consuming errors that are made when using paper ordering forms. Many of these programs also let the dispenser check the status of the jobs in the lab in real-time. Finally, these software programs can be connected to a remote frame tracer that will create a digital file of the frame's exact shape and attach it to the order. Once the lab has completed the order and sends the lenses to your office, they are already edged to the shape of the frame and ready for you to mount them into the frame. All the while, the frame never had to leave the office!

The amount of information the lab needs will vary for each patient but, in general, laboratory order forms, paper or electronic, have four areas that need to be filled in before the Rx can be processed.

## PATIENT INFORMATION AND Rx

Patient Name <input type="checkbox"/> Mail to Patient		Order Date	<input type="checkbox"/> Cut & Edge	Invoice Number
			<input type="checkbox"/> Uncut	
Address Street		Date Needed		Original Invoice Number
City	State	Zip		

Sphere	Cylinder	Axis	Prism/Base	Decenter	Distant PD	Near PD	
R ①	①	①	①		③	⑧	
L ①	①	①	①		③	⑧	
Add	Near Inset	Total Inset	Seg. Height	OC Height	Center Thickness	Edge Thickness	Temper
R ④			⑦	⑧			<input type="checkbox"/> Heat <input type="checkbox"/> Chem
L ④			⑦	⑧			

## LENS INFORMATION

Material	Lens Style	Seg Style	Base Curve	Blank Size
<input type="checkbox"/> Plastic _____	<input type="checkbox"/> SV: ⑤	⑥	R	R
<input type="checkbox"/> Glass _____	<input type="checkbox"/> Bifocal:		L	L
<input type="checkbox"/> High Index _____	<input type="checkbox"/> Trifocal:		Lens Coating/Lens Tint	
<input type="checkbox"/> Polycarbonate _____	<input type="checkbox"/> Progressive:			
<input type="checkbox"/> Other _____	<input type="checkbox"/> Other:			

②

SCRATCH COAT:  BOTH SIDES  FRONT ONLY AR COAT:  MULTI-LAYER  SINGLE-LAYER

## FRAME INFORMATION

<input type="checkbox"/> SUPPLY	<input type="checkbox"/> ENCLOSED	<input type="checkbox"/> TO COME	<input type="checkbox"/> LENSES ONLY
<input type="checkbox"/> ZYL	<input type="checkbox"/> METAL	<input type="checkbox"/> DRILL	<input type="checkbox"/> GROOVE <input type="checkbox"/> FACET BEVEL <input type="checkbox"/> HALF EYE
Frame Name	Color	Eye Size	Bridge <input type="checkbox"/> AP <input type="checkbox"/> FF Temple <input type="checkbox"/> SK <input type="checkbox"/> CC
Manufacturer	Frame or Pattern #	Frame Measurements	Shape Code
	A	B ED:	

Other Rx Information	
----------------------	--

## Patient Information

Include all patient information that will be needed to process the eyewear order and deliver the finished product. This section usually has a place for the date ordered, the date needed, the invoice number and any other necessary information about the patient. NOTE: If the eyewear is needed by a certain date, be specific. Avoid just saying "Rush."

## Lens Information

Lens information will vary by the lens type ordered. You will have to supply facial measurements for this area. Lens enhancements such as S/R , A/R or UV treatments will also be listed here. Referring to the sample form, the information needed by lens type is as follows:

### Single Vision

- ① Rx
- ② Lens material
- ③ PD Measurement

### Bifocal

- ① Distance Rx
- ④ Reading add power
- ② Lens material
- ⑤⑥ Bifocal shape and size
- ⑦ Bifocal seg height
- ③⑧ PD measurement for distance and near

### Trifocal

- ① Distance Rx
- ④ Reading add power
- ② Lens material
- ⑤⑥ Trifocal shape and size
- ⑦ Trifocal seg height
- ③⑧ PD measurement for distance and near

### Progressive Addition Lenses

- ① Distance Rx
- ④ Reading add power
- ② Lens material
- ⑤⑥ PAL Type
- ⑦⑧ Fitting height
- ③ Distance measurement for monocular PD

## Frame Information

Frame information needed by the laboratory will include how the frame will arrive (such as “frame to come” or “lab-supplied”) unless the order is for lenses only. The type of edge to be placed on the lenses should be noted. Include as much information about the frame as possible. Frame dimensions such as A, B, DBL, ED and circumference may be needed. Always try to enclose or have the frame sent to the laboratory before the lenses are processed. This provides the best blueprint of the exact lens size and shape needed.

## Other Information

This section of the form is used for specific information needed to complete the Rx order.

## Conclusion

There are several ways to relay your order to the lab. Orders can be placed on-line, faxed, telephoned, or mailed. Whatever method is used to send orders to the lab, some general rules apply to all methods that will help make the process smoother.

- Have all information ready.
- Write legibly.
- Communicate clearly and avoid rushing the customer service person receiving your order.
- If additional information is requested, follow-up promptly.

Take the time to be sure the order is complete and correct before it is sent to the lab. Ask questions and confirm choices before you send the order. The time spent preparing the order will save time and delays in correcting an order. Getting the order right the first time will give you the fastest, most efficient, and most cost-effective service from the lab.

The most successful dispensing and the most satisfied patients always result from the most accurate order preparation.

You and your laboratory partner are a team. As with any team, the better you work together, the more you both will succeed. In the end, your patient will be the winner.

# DELIVERY OF EYEWEAR TO THE PATIENT

The process of dispensing eyewear to the patient is accomplished in different steps. The first step is already completed, the selection of lenses and frames. This first step is most important, as it determines your successful fitting for comfort, cosmetics and visual performance. Proper lens and frame selection makes the remaining steps easy to accomplish.

## Frame Alignment Process

Standard alignment is the starting point and benchmark in all adjustments. All frames should be in standard alignment condition in four situations.

1. On the frame boards: Standard alignment allows the patient to try on frames without the frames feeling too large or small.
2. Verifying or Neutralizing: When determining lens power, the frame must be aligned properly so the characteristics can be determined in these proper positions.
3. Delivery: The first time you place the finished eyewear on the patient, you will create a lasting impression of how the patient feels about his or her new eyewear. Using proper standard alignment, make sure it's a good impression.
4. Problem adjustments: Sometimes it is best to start from the beginning. Place problem adjustments in standard alignment first.

### To place a frame in standard alignment:

1. Make sure all the screws are tight. Inspect the frame carefully; look for cracks.
2. Starting with the front, check for proper face form.

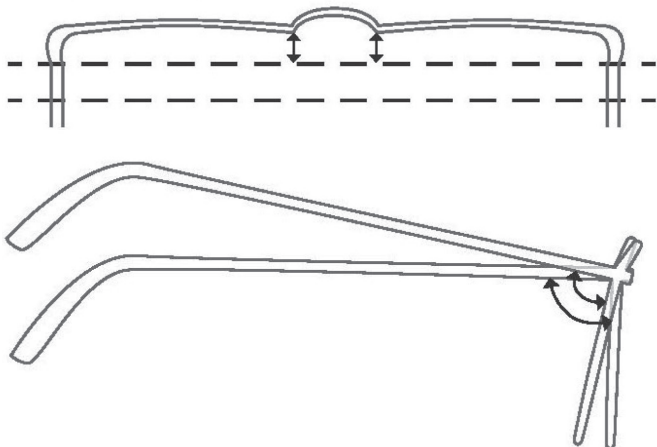

3. Check for X-ing (twisting) from the top side.
4. Check for even pantoscopic angle on both the right and the left side, using the four point table-touch test

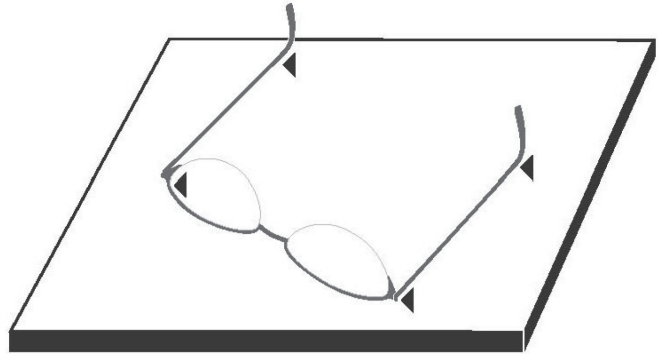

5. Adjust to correct pantoscopic angle—8 to 12 degrees.

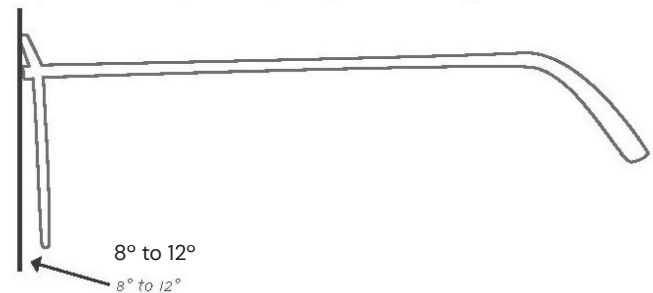

6. Temple spread with front should be 90°.

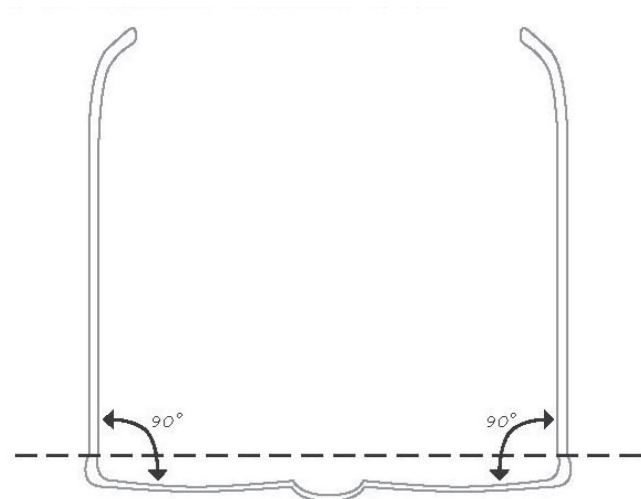



7. Temples should fold one over the other provided they don't touch the lens surfaces.



If all of the above check out ok, you're on your way. If not, you have to adjust the frame to achieve each adjustment point. Here are some helpful hints to achieve standard alignment.

1. Don't force a screw to turn. Find out what's binding it.
2. The face form can be changed by heating the bridge area of plastic frames when bending the frame. Hold the frame near the bridge when bending to prevent breakage. (Use caution when heating frames).
3. Follow step number two to correct X-ing (twisting).
4. To change the pantoscopic angle, brace the front hinge using pliers or your hands. Hold the temple near its hinge, close the temple slightly and bend up or down. This is a cold bend. Do not heat.
5. Check the bridge and endpieces of the frame for proper front-temple spread. The temple spread can be decreased by bowing the bridge or bringing in the endpieces; it can be increased by reducing the front face form or bringing the endpieces out.
6. The temple fold can be changed by bending the hinge. This is also a cold bend. Do this bend with the temples closed.

## Nosepads

How the nosepads fit (correct width and pad contact) should be evaluated during the frame selection process. With a plastic frame, the width of the nosepads should be wide enough to allow the bridge to sit on the sides of the nose. If the bridge is too wide, it will rest on the top of the nose. A too-small bridge will show a space between the bridge and the top of the nose. Frames with adjustable pads should have a bridge wide enough to allow pad adjustment.

Adjustable nose pads must be adjusted to achieve total pad contact on the side of the nose. To check for proper contact observe:

1. The fit at the top and bottom of the pad.



2. The fit on the front side and back side of the pad.



3. That the vertical angle of the pad is tilted with the bottom of the pad toward the frame to follow the shape of the nose.

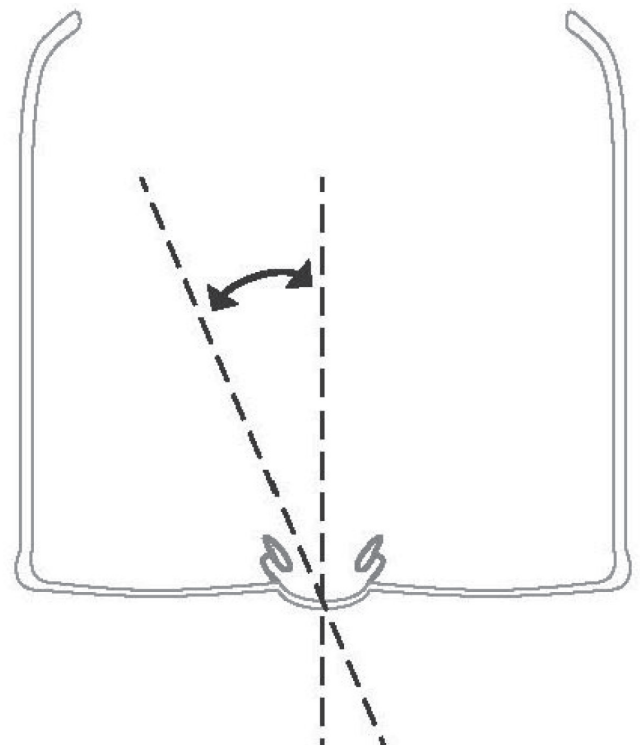

## Adjustment for Alignment

There are two different situations that require adjusting eyewear to proper alignment. One is the first-time fit and the other is readjusting the eyewear to proper alignment. Regardless of which one you are doing, these tips will help you in the process.

- Take time to develop the adjustment pattern that works for you.
- Follow office procedures and policies.
- Inspect the eyewear and inform the patient of current eyewear conditions before adjusting.
- Adjust with confidence.
- Explain proper care, cleaning and maintenance.
- Use standard alignment as your guide for adjusting for facial features.

End on a positive note, thank them, and invite them back.

## New Delivery

New eyewear is fun to adjust. The frame is shiny, the lenses clear and crisp and the patient is anxious to see his or her new eyewear. This should be a snap, right? Not always. Here is a guide to adjusting new eyewear.

### Before the patient is notified:

- Verify the Rx.
- Place eyewear in standard alignment.
- Clean and place the eyewear in a delivery case.

### When the patient arrives:

- Compliment the patient on the choice of frame and lenses.
- Explain what you are going to do.
- Keep control of the dispensing process.

### At the end of the adjustment:

- Check for proper pressure and fit.
- Explain what the new eyewear will do to meet the patient's visual needs.
- Explain proper care and maintenance of frame and lenses.
- Make sure all questions are answered.
- Close the dispensing process in a positive manner.

When adjusting the new frame, first place it on the patient's face. Approach the patient with the temples turned down from the eyes. As you reach the ears, raise the temples and place over the ears. If the patient wants to put on the eyewear, that's fine. Observe the placement and then start the adjustment process.

Check the front first. The frame front should be positioned level with the eyes. Fit the eyes, not the eyebrows. See if the bottom or top of the frame is too close to the face. Check the pantoscopic angle from the side. Observe the distance of the frame front from each eye. This distance amount should be equal. Align the front relative to facial features.

## Review

1. Follow manufacturer recommendations when dispensing lenses and frames.
2. Check the front first. The frame front should be positioned so the eyes are level in the eyewire.
3. Observe if the bottom or top of the frame is too close to the face. Check the pantoscopic angle of the frame from the side.
4. Observe the distance of the frame front to the eyes at the top and bottom of the frame. The distance should equal.
5. There should be no side pressure from the temples before the ear. The temples should run back touching but not creating pressure. Side bow if necessary.
6. The temple bend at the top of the ear should be made about 1/4-inch behind the ear.
7. Contour the temple from the top bend to the tip to create friction.
8. Check the overall fit for comfort and snugness.

## Readjustments

When a patient returns for a readjustment because his or her eyewear is out of alignment, you first have to locate the problem area and then determine the method of correction. Asking questions and observing will lead you to the problem area. If you have options to correct the alignment, choose the one that will present the least stress to the frame and lenses. Always inspect the eyewear condition in front of the patient and point out any potential problems, such as small cracks or weak spots, before attempting to adjust the frame. Check the final alignment following the points listed above.

# GLOSSARY OF TERMS

## Common Optical Terms and Abbreviations

Optical terminology is an important part of our day-to-day office and laboratory communication, but it can make communication in the office between the patient and dispenser difficult. As terms become familiar to you, remember that your patients may not understand what you mean when you use optical terminology and you, in turn, must be open to their descriptions and definitions. A patient may call a temple a “wing,” an “arm” or a “leg,” but what is important is that you both know which part you are talking about.

Some common optical terms that you should be familiar with include:

**Add:** The additional plus power amount needed for near vision; it is sometimes referred to as the add power or seg power.

**Astigmatism:** This visual condition is caused by light entering the eye and coming to two separate focus points. It is corrected with a cylinder lens prescription in a certain direction.

**Axis:** The direction or angle of the cylinder between zero and 180 degrees, measured from a horizontal line counter-clockwise when looking at the patient.

**Chromatic Aberration:** Unequal refraction of different wavelengths of light, commonly producing colored fringe around an image.

**Cylinder:** A prescribed amount of power that is added or subtracted to the lens sphere power to create two different powers in the principal meridians.

**ECP:** Abbreviation for Eyecare Provider

**Farsighted:** Called hyperopia, this is a visual condition where the patient can see far away but not near without visual aids. It is corrected with a plus (+) prescription such as +1.00 D (diopter).

**Front:** The part of the frame that consists of two eyewires and the bridge.

**Hinge:** Metal pieces that are held together by a screw attached to the front endpiece and temple ends.

**Nearsighted:** Called myopia, this condition causes a patient to be able to see near but not far away without visual aids. It is corrected with a minus (-) prescription such as -1.00 D.

**Nosepads:** Plastic pieces attached at the bridge area to distribute the weight of the eyewear on the nose.

**O.D.:** Right eye; an abbreviation for the Latin term oculus dexter.

**O.S.:** Left eye; an abbreviation for the Latin term oculus sinister.

**Optical Center:** The center point of a lens where light passes through and does not bend.

**Pantoscopic Angle:** Angle of the frame front from the face.

**Pupillary Distance (PD):** The distance in millimeters between the center of the eyes. This measurement can be taken for distance viewing (far PD) or near viewing (near PD).

**Presbyopia:** The loss of accommodation or the loss of the ability of the eye to increase power when looking from far to near, for example, when reading. It usually begins in middle age and is corrected by multifocal or reading lenses.

**Prescription:** Written form of the necessary lens power to correct a patient’s vision; it is usually written as Rx.

**Sphere:** Surface having the same curve in all meridians; or, a lens having the same power in each meridian.

**Temples:** Stems attached to the front endpiece; they are usually contoured around the ears.

**Vertex Distance:** A straight line measurement in millimeters from the back surface of a mounted spectacle lens to the apex of the cornea.

# INDEX

## A

**Accommodation** 9, 11, 39  
**Add power** 18–19, 33, 35, 39  
**“A dimension”** 27–28  
**Adjustment** 29, 30, 37, 38  
*see also readjustment*  
**Anatomy of the Eye** 8  
**Anterior Chamber** 8  
**Anti-reflection** 20–23  
**A/R**, *see anti-reflection*  
**Aqueous humor** 8  
**Assembly** 6  
**Astigmatism** 10, 12, 17, 23, 39  
**Axis** 12, 17, 39

## B

**“B” dimension** 27, 28  
**bifocal lens** 11, 19  
**Blocking** 5, 6  
**Boxing system** 27  
**Bridge** 25, 27, 29, 30, 32, 37, 39  
    keyhole 30  
    saddle-style 30  
    types 30, 31

## C

**Cellulose acetate** 3, 28  
**Choroid** 8  
**Chromatic aberration** 39  
**Ciliary muscle** 8  
**Clear Choices brochure** 23, 24  
**Coatings**  
    anti-reflective 16  
    color 22  
    mirror 16, 22

**Color coatings** 22  
**Computer lens** 19  
**Conjunctiva** 8  
**Converging lens** 9, 11  
**Cornea** 8, 9, 10, 26, 39  
**Corneal reflection pupilometer** 25  
**CR-39** 13, 14  
**Crown Glass** 13, 14  
**Crystalline Lens** 8, 9, 11  
**Customer service** 5, 35  
**Cylinder power** 17

## D

**DBC** 27–28  
**DBL** 27–28, 35  
**Deblocking** 5  
**Decentration** 13, 28  
**Delivery of eyewear** 6, 36–38  
**Density** 14–16, 22  
**Dimension “A”**, 27  
**Dimension, “B”** 27–28  
    frame PD 28  
    vertical height 27  
**Dispensing** 23, 33–38  
**Donders, Dr.** 3

## E

**ECPs**, *see eyecare provider*  
**ED**, *see effective diameter*  
**Edge treatments** 22  
**Edging** 6, 22  
    hand edging 6  
**Effective diameter** 27  
**Electromagnetic spectrum** 14  
**Emmetropic eye** 9  
**Endpiece** 29, 39

## Eye

- anatomy 8
- emmetropic 9
- farsighted 9
- hyperopic 9
- myopic 10
- nearsighted 10
- normal 9
- presbyopia 11
- spherical lens of, 10

**Eyecare provider 13, 14, 39**

**Eyesize 27, 28, 32**

## Eyewear

- adjustment 29–30, 37–38
- bundling 33
- delivery of, 6, 36–38
- history of, 3–4
- inspection of, 5, 6
- packaging 33
- selection of, 27–32

**Eyewires 27**

## F

**Face shapes**, *see facial characteristics*

**Facial characteristics 32**

**Facial measurements 5, 14, 25, 32, 35**

**Farsighted 9, 39**

**Fining 5**

**Finishing department 5, 6**

**Flow Chart, Rx 7**

**Fovea 8**

## Frame

- alignment 14, 36
- children's 31
- colors 32
- combination 29
- cosmetics 29, 32, 33
- drilled rimless 15, 16, 29
- front 27–32

full 29

grooved rimless 29

half-eye 30

hinge 37, 39

materials 28–29

measurements 27–28

metal 28–29

monel 29

nylon 29

plastic 28–29

prescription information and 33

propionate 28

rimless 29

safety 30

selection of, 27, 29, 32, 33

size 28

sports 29–30

stainless steel 29

standard alignment 36–38

styles 28

titanium 29

**Frame-front 26, 28, 32, 38, 39**

**Frame PD 28**

## G

**GC**, *see geometric center*

**Generating 5**

**Geometric center 27**

**Glass 3, 14–16, 20–22**

**Glossary of Terms 39**

## H

**Hand edging 6**

**Helmholtz, Professor 3**

**High index 16**

**Hinge 37, 39**

**History of eyewear 3–4**

**Hyperopes 9, 11**

**Hyperopia 9**

**Hyperopic 9**

## I

**Index of refraction 13, 15, 16**

**Infrared 14**

**Inspection 5, 6**

**Iris 8**

## K

**Keyhole bridge 30**

## L

**Laboratory 4–6, 14, 16, 20, 21, 23, 28–30, 34, 35, 39**

**Laboratory order 6, 34**

**Layout 6**

**Lens 3–6, 9–30, 32, 33, 35–37, 39**

anti-reflection 20, 23

bifocal 3, 11, 19, 26

color 20

computer 19

concave 5, 10, 12

converging 9, 11

CR-39<sup>®</sup> 13, 14

density 14, 15, 16, 22

diverging 10, 12

enhancements 16, 17, 20–24, 33

finished 5

glass 16, 20, 21, 22

inspection 5, 6

invisible 17

marking 26

measurements 26

minus 10, 12, 13, 17, 22, 23, 28, 39

mirror-coated 11, 16, 22

multifocal 16, 39

no-line bifocals 11, 17

occupational 19

office 19

personalized 18

photochromic 3, 22

plastic 3, 4, 13–16, 20–22

plus 11, 13, 23, 28

prescription information 33

progressive addition 3, 4, 11, 17, 18, 20, 25, 26, 32

reading 17, 19, 30, 32

scratch resistant 5, 15, 16, 20

selection of, 13, 15, 17

semi-finished 5, 18

single vision 17, 19, 26

specialty 20

sphero-cylinder 10, 12

styles of, 17

surfacing of, 5, 18

task-specific 19

thickness 13

tints 16, 20, 21

treatments 6, 16, 17, 20–24, 33

trifocal 11, 19, 26, 35

weight 14

**Lens enhancements 5, 20–24, 33**

**Lens materials 13–16**

**Lens pick 7**

**Lens segment 19**

**Lens treatments 5, 6, 16, 17, 20–24, 33**

**Lifestyle 23**

questionnaire 23

**Ligaments, suspensory 8**

**Light transmission 14, 20, 21**

**Limbus 8**

## M

**Macula area** 8

**Mark-up** 5

**Measurement** 25–28

facial 25–26

frame PD 27

vertical height 26

**Metals** 29

**Mid-Index** 15

**Minus lens** 10, 12, 13, 17, 22, 23, 28, 39

**Mirror coating** 11, 16, 22

**Monel** 29

**Multifocal lens** 16, 39

**Myopia** 10, 39

**Myopic** 10

## N

**Nearsighted** 10, 12, 39

**Neutralizing** 36

**Nosepads** 37, 39

**Nylon** 29

## O

**Occupational lens** 19

**O.D.** 39

**Office environment lens** 19

**Ophthalmologist** 3

**Optician** 3

**Optometrist** 3

**O.S.** 39

## P

**PALS**, *see Progressive addition lens*

**PD**, *see Pupillary distance*

**Pantoscopic angle** 26, 36, 37, 38

**Patient**

information 34

lifestyle questionnaire 23

**Personalized** 18

**Photochromic lenses** 4, 22

**Plastic** 3, 4, 13–16, 20–22, 28–32, 39

CR-39<sup>®</sup> 13, 14

frames 28

high index 16

mid-index 15

Polycarbonate 15

Trivex<sup>®</sup> 15

**Plus lens** 11

**Polarized lens** 22

**Polishing** 5

**Polycarbonate** 4, 13, 14, 15

**Posterior chamber** 8

**Presbyopia** 11, 19, 39

**Prescription** 3, 17–20, 23, 26, 30, 33, 39

**Prescription form** 33

**Presentation process** 23

**Progressive addition lens** 3, 4, 11, 17, 18, 20, 25, 26, 32

**Progressive lens**, *see Progressive addition lens*

**Progressive lenses**, *see Progressive addition lens*

**Propionate** 28

**Pupil** 8, 25, 26

**Pupillary distance** 25, 39

measurement 25

# INDEX

## R

**Radiant energy** 14  
**Readjustment of eyewear** 38  
**Retina** 8, 9, 10, 11, 12  
**Rx**, *see Prescription*

## S

**Saddle-style bridge** 30  
**Sclera** 8  
**Scratch resistant** 5, 15, 20  
**Seg**, *see Segment*  
**Segment** 19, 20, 26  
**Single vision lenses** 11, 17, 19  
**Specialty Lens** 20  
**Sphere** 17, 18, 39  
**Sphero-cylinder lens** 10, 12  
**Stainless steel** 29  
**Standard alignment** 36  
**S/R**, *see Scratch resistant*  
**Sunglasses** 22, 24, 30  
**Sun lenses** 22  
**Surfacing department** 5  
**Suspensory ligaments** 8

## T

**Task-specific lens** 19  
**Temples** 27, 29, 30, 31, 37, 38  
    comfort cable 31  
    length of 31  
    library 31  
    riding bow 31  
    skull 31  
**Tints** 6, 16, 20, 21

**Titanium** 29

### Treatments

    anti-reflection 16, 20, 21  
    edge 22  
    lens 20  
    scratch-resistant 20  
    ultraviolet 14, 21, 23

**Trifocals lens** 19

**Trivex®** 15

## U

**Ultraviolet** 14, 21, 23  
    protection 15, 16, 21  
    radiation 14, 15, 21, 22  
**UV**, *see Ultraviolet*

## V

**Vertex Distance** 26, 39  
**Vertical Height Measurements** 26  
**Visible light** 14  
**Vitreous humor** 8

## Z

**Zyl** 28











225 Reinekers Lane, Suite 700, Alexandria, VA 22314

(800) 477-5652

[thevisioncouncil.org](http://thevisioncouncil.org)